 Reliability Creativity Service	Product Specifications		FZ01-360B1	1/4
	Flow Sensor		Model	ND□□-□ATAA□-RC

1-1. Specifications (ND05 / ND10)

Model	ND05-N	ND05-P	ND05-T	ND10-N	ND10-P		ND10-T
	ATAAC-RC	ATAAC-RC	ATAAA-RC	ATAAA-RC	ATAAA-RC	ATAAC-RC	ATAAA-RC
Nominal diameter	5mm			10mm			
Accuracy guaranteed flow-rate range	0.3 to 3.0 L/min			1.5 to 20 L/min		1.0 to 10 L/min	
Accuracy	±2%RS (At the standard installation position)						
Fluid to be measured	For water and hot water	For water and chemical fluids Note) Please select suitable model by checking whether the wetted parts main materials have resistance against your liquid to be measured.		For water and hot water	For water and chemical fluids Note) Please select suitable model by checking whether the wetted parts main materials have resistance against your liquid to be measured.		
Fluid viscosity range	0.5 to 1.5 mPa·s(Equivalent to water)						
Fluid temperature range	0 to +70°C	0 to +60°C		0 to +70°C	0 to +60°C		
Working ambient temperature/humidity range	-10 to +70°C35 to 85%RH (No dew condensation)						
Maximum working pressure	1MPa (at the fluid temperature of 20°C)						
Pressure drop (at the accuracy guaranteed maximum flow-rate)	12 kPa or less			20 kPa or less		15 kPa or less	
Output signal	NPN Open collector pulse Maximum load24VDC6mA , Duty ratio3:7<ON:OFF<7:3						
Signal cable	Lead wire length: Approximately 600mm4-core AWG26 flat cable (Red: Power +/Black GND/White: Output/Blue: Feedback)						
Pulse constant	2.5 mL/P			7.69 mL/P			
Maximum frequency (at the accuracy guaranteed maximum flow-rate)	20Hz			Approximately 44Hz		Approximately 22Hz	
Minimum pulse ON time	15msec			Approximately 6.9msec		Approximately 13.8msec	
Standard installation position ¹⁾	Position so that the brand mark (AC mark) on the name plate faces up against the ground						
Flow direction	Arrow direction indicated on the product						
Pipe connection	R 1/2						
Protection grade	indoor specifications (Equivalent to IP X4)						
Power supply	3 to 24 VDC Same voltage level should be applied to the sensor power (red-black) and pulse output (blue/white-black).						
Power consumption	5mA or less						
Weight	Approximately 150g			Approximately 120g			
Main materials of wetted parts ³⁾	Casing	Modified PPO	PP	ETFE	Modified PPO	PP	ETFE
	Vane wheel	CF-POM		ETFE	CF-POM		ETFE
	Pivot	SUS304	PA	ETFE	SUS304	PA	ETFE
	O-ring	NBR	FKM		NBR	FKM	
	Magnet	Sa-Co ²⁾			Ba-Fe		Sa-Co ²⁾
Others	CE Marking product , RoHS directive corresponded						

 Reliability Creativity Service	Product Specifications		FZ01-360B1	2/4
	Flow Sensor		Model	ND□□-□ATAA□-RC

1-2. Specifications (ND20)

Model	ND20-N ATAAA-RC	ND20-P ATAAA-RC	ND20-P ATAAC-RC
Nominal diameter	20mm		
Accuracy guaranteed flow-rate range	3.0 to 60 L/min		
Accuracy	±2%RS (At the standard installation position)		
Fluid to be measured	For water and hot water	For water and chemical fluids Note) Please select suitable model by checking whether the wetted parts main materials have resistance against your liquid to be measured.	
Fluid viscosity range	0.5 to 1.5 mPa·s(Equivalent to water)		
Fluid temperature range	0 to +70°C	0 to +60°C	
Working ambient temperature/humidity range	-10 to +70°C35 to 85%RH (No dew condensation)		
Maximum working pressure	1MPa (at the fluid temperature of 20°C)		
Pressure drop (at the accuracy guaranteed maximum flow-rate)	60 kPa or less		
Output signal	NPN Open collector pulse Maximum load24VDC6mA Duty ratio3:7<ON:OFF<7:3		
Signal cable	Lead wire length: Approximately 600mm4-core AWG26 flat cable (Red: Power +/Black GND/White: Output/Blue: Feedback)		
Pulse constant	25 mL/P		
Maximum frequency (at the accuracy guaranteed maximum flow-rate)	40Hz		
Minimum pulse ON time	7.5msec		
Standard installation position ^{*1}	Position so that the brand mark (AC mark) on the name plate faces up against the ground		
Flow direction	Arrow direction indicated on the product		
Pipe connection	R 3/4		
Protection grade	indoor specifications (Equivalent to IP X4)		
Power supply	3 to 24 VDC Same voltage level should be applied to the sensor power (red-black) and pulse output (blue/white-black).		
Power consumption	5mA or less		
Weight	Approximately 360g		
Main materials of wetted parts ³	Casing	Modified PPO	PP
	Vane wheel	CF-POM	
	Pivot	SUS304	
	O-ring	NBR	FKM
	Magnet	Ba-Fe	
Others	Sa-Co ^{*2}		
CE Marking product , RoHS directive corresponded			

 Reliability Creativity Service	Product Specifications	FZ01-360B1	3/4
	Flow Sensor	Model	ND□□-□ATAA□-RC

*1: The standard installation position means the position that the brand mark on the nameplate (AC mark) faces upward against the ground.

Also, note that durability of the product is deteriorated in case of installation positions other than the standard installation position because amount of wearing is to be increased.

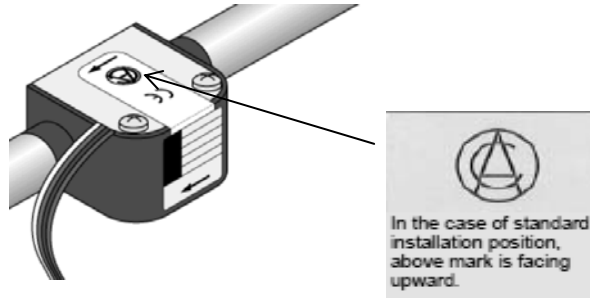



*2: This magnet is not in touch with liquid.

*3: Material symbols

Modified PPO	Glass fiber reinforced NORYL (Polyphenylene oxide)
PP	Polypropylene
ETFE	Fluororesin (Ethylene-tetrafluoro ethylene)
CF-POM	Carbon-fiber-filled Polyacetal or Polyoxymethylene
PA	Polyamide
SUS304	Stainless
FKM	Fluoro Rubber
NBR	Nitrile Rubber (Acrylonitrile-Butadiene Rubber)
Sa-Co	Samarium-Cobalt
Ba-Fe	Barium-Ferrite

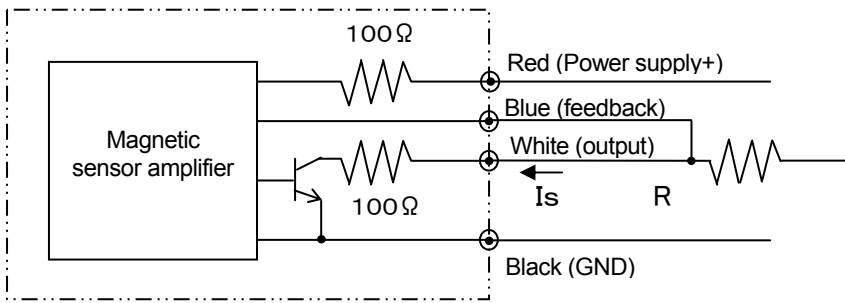
2. Wiring technique

NPN Open collector pulse output	<p>Flowsensor</p>  <p>The pull-up resistance R for the open collector output side should be 50KΩ or less. However, output suction current must be not more than 6mA.</p> $I_s(\text{output sink current: mA: mA}) = \frac{V(\text{Power supply voltage: V})}{R(\text{Pull-up resistance: k}\Omega)} \leq 6\text{mA}$ <p>Applied voltage of sensor power supply (Red – Black) and pulse output (Blue/White-Black) shall be the same.</p>
---------------------------------	---

 Reliability Creativity Service	Product Specifications	FZ01-360B1	4/4
	Flow Sensor	Model	ND□□-□ATAA□-RC

3. Precautions for handling

3-1. Working environment, fluid to be measured

- (1) Ensure that the wetted parts' materials have corrosion resistance against fluid to be measured.
- (2) Keep the product away from a strong magnetic field or a source of electric noise.
- (3) The product is not explosion-proof specification. Do not use the product in an explosive atmosphere such as flammable gas, etc.
- (4) In case flow in the pipe has pulsation, the measurement accuracy is to be affected. When feeding the fluid with a constant rate pump, etc., which causes pulsation of flow, cancel the pulsation using an accumulator, etc.
- (5) Avoid installation at a place exposed to direct sunlight and/or rain (Indoor specification).

3-2. Precautions for piping

- (1) No air shall be in the fluid to be measured. The measurement accuracy is to be affected.
Do not install the product at a place where air accumulation can easily occur (e.g. upstream side of a falling pipe).
Also, before start measurement, remove air sufficiently.
- (2) For the installation position, install the product in the standard installation position (The brand mark on the nameplate faces upward against the ground).
- (3) Devices such as a flow-rate adjusting valve, etc., which disturb flow shall be installed in the downstream of the flowsensor.
- (4) Avoid installing the product where it is exposed to excessive pressure, such as water hummer, etc.
- (5) In case foreign substances, oil, etc., exist in the piping, install the flowsensor after cleaning inside of the pipe.
- (6) Make sure to align the flow direction of the fluid with the flow direction indicated by the arrow on the main body.
- (7) Provide straight pipe portion of 5D or more at the upstream and 3D or more at the downstream of the flowsensor.
- (8) Around the place of installation, provide enough space for maintenance.