

**Ultrasonic Flow Meter for  
Management of Fuel Gas**

**ATZTA    UX /UZ**

**Model:    UX40 UX50**

**UZ40    UZ50**

**Operation Manual**



## Introduction

Thank you very much for purchasing the High performance Ultrasonic Flow Meter UX/UZ Series for Fuel Gas this time. Please be sure to read this Operation Manual to use this product correctly and safely and to prevent accident.

Please arrange for operators who actually use this product to know the context of this Operation Manual surely. This Operation Manual is necessary for performing maintenance, too. Please keep the Manual in a safe place until this product is disposed of.

## Confirmation of package contents

Upon delivery of the product, confirm that the following items are contained in the package before using the product:



Name	Quantity	Remarks
Ultrasonic flow meter	1	
Operation manual (this document)	1	
Hexagonal wrench	1	
Flange gasket	2	Option
Bolt set (Bolts, plain washers, nuts)	8	Option



If there is any incorrect item , shortage, or any defect in the external appearance, please contact your nearest branch or sales office.

## Safety concerns

To ensure the safe use of this product and to prevent an accident or an unexpected situation, instructions to which attention must be paid are indicated with the following symbols.

### Structure of warning indications

 <b>Danger</b>	Incorrect handling by ignoring to follow instructions of this symbol may lead to imminent danger of death or serious injury.
 <b>Warning</b>	Incorrect handling by ignoring to follow instructions of this symbol may lead to possibility of death or serious injury.
 <b>Caution</b>	Incorrect handling by ignoring to follow instructions of this symbol may lead to injury and/or properties loss (product damage, etc.).

	This symbol indicates acts requiring “caution” and that improper operation may result in an accident.
	This symbol indicates “prohibited” acts.
	This symbol indicates “mandatory” acts that you should observe strictly.

## Precautions for use

 <b>Danger</b>	<ol style="list-style-type: none"><li>1. Do not use for applications that require safety, such as nuclear, railroad, aircraft, vehicle, playground equipment, etc.</li><li>2. Do not modify the product.</li><li>3. Do not use the product for foods, drinks, medical purposes, etc., because it is not designed for sanitary specifications.</li><li>4. Do not use the product in the atmosphere of an inflammable gas, etc., because it is not designed for explosion-proof specifications. The meters do not conform to ATEX (explosion-proof) directive (2014/34/EU).</li></ol>
--	---

## Working environment and applicable fluid



### Working environment and applicable fluid

 <b>Caution</b>	12. When installing it at the upstream or downstream of the governor, install it 10D or more away from the governor. (An incorrect flow-rate measurement may occur due to an effect of the governor.)
	13. After the subject fluid for measurement is set, turn on the power while no fluid flows (0 m <sup>3</sup> /h).
	14. Since the variance of the instantaneous flow-rate may become larger due to an effect of the governor, it is recommended to set 16 times to the instantaneous flow-rate moving average number of times.









### Cautions for operations

 <b>Caution</b>	This product is not a specified measuring instrument defined in Japanese measurement law.
---	---

### Storage

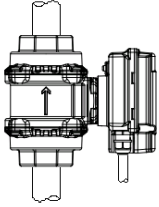
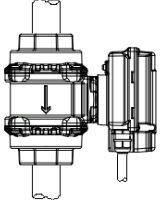
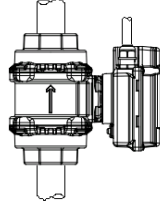
 <b>Caution</b>	<ul style="list-style-type: none"><li>⊘ 1. Store the flow meter at a place away from fire and not exposed to direct sunlight.</li><li>⊘ 2. Do not place any combustible material, inflammable substance and heating body in the periphery of the flow meter.</li><li>ⓘ 3. Store this product at a place whose ambient temperature is -20 to +70°C and where no dew condensation occurs.</li></ul>
---	---

## Piping

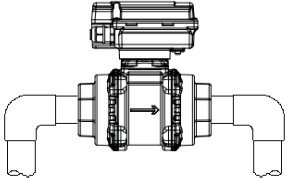
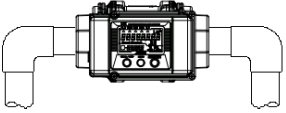
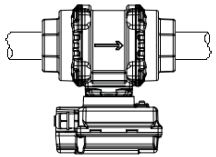
 <b>Warning</b>	<ul style="list-style-type: none"> <li>⊘ 1. Do not climb on this product using it as a foothold.</li> <li>⊘ 2. Do not carry and/or install this product as holding its display.</li> </ul>
 <b>Caution</b>	<ol style="list-style-type: none"> <li>1. When you install the flow meter, be sure to turn off its power. After the flow meter is installed, set the subject fluid for measurement and turn on the power while no fluid flows (0 m<sup>3</sup>/h).</li> <li>2. In the case of new piping, install the product after sufficient cleaning of the pipe(s).</li> <li>3. It is recommended to use rising piping to install the flow meter if the air contains oil mist, dust, or other materials. If oil mist and/or dust accumulates inside this product, it may cause performance failure and/or defects. Installation in which the display part faces downward and the cable introduction part faces upward cannot be performed.</li> </ol> <div style="display: flex; justify-content: space-around; align-items: flex-start; margin-top: 20px;"> <div style="text-align: center;">  Recommended         </div> <div style="text-align: center;">  Not recommended         </div> <div style="text-align: center;">  Incorrect         </div> </div> <div style="display: flex; justify-content: space-around; align-items: center; margin-top: 10px;">    </div> <div style="display: flex; justify-content: space-around; align-items: flex-start; margin-top: 20px;"> <div style="text-align: center;">  Correct         </div> <div style="text-align: center;">  Correct         </div> <div style="text-align: center;">  Incorrect         </div> </div> <div style="display: flex; justify-content: space-around; align-items: center; margin-top: 10px;">    </div> <ol style="list-style-type: none"> <li>4. Do not install the flow meter in sections where it will be subjected to significant compression forces, tensile loads, and other loads after it is installed.</li> <li>5. Install the product along with the flow direction indicated on the product.</li> <li>6. Do not drop the product, hit it, or apply excessive impact.</li> <li>7. When turning the display unit, do not apply force to any direction other than the rotational direction. In case any force is applied to direction to pull up or push down the display, the display may come off which can lead to breaking of the internal wires, etc., or may not rotate smoothly.</li> <li>8. When making piping connections, make sure that foreign material such as weld chips, debris, and sealant do not make their way into the pipe.</li> <li>9. When tightening the pipe, do not apply excessive torque.</li> <li>10. For the basic type of UZ, use a 55-mm hex bolt to avoid interference with the display section and body. (Recommended bolt specification: M16 x 55 mm).</li> <li>11. Installation of a strainer (60 meshes) at the upstream side of the meter is recommended. (In case of dust adherence on the internal mechanism portion, the flow meter may not be able to satisfy the measurement accuracy.)</li> </ol>

## Wiring



**Danger**

1. When performing wiring work, follow the instructions in this Operation Manual.



## Disassembling and inspection

 <b>Caution</b>	<ul style="list-style-type: none"><li>1. Do not disassemble this product.</li><li>2. When fluid flow is normal, the pilot lamp will blink. If it does not blink, please contact the company you purchased the product from or our branch or sales office.</li></ul>
---	---

## Disposal

 <b>Warning</b>	<ul style="list-style-type: none"><li>1. This product contains a lithium battery, and therefore be sure not to dispose it in the general disposal route. [Internal Battery Type]</li><li>2. Be sure not to put this product into fire. It may cause fire and/or explosion.</li><li>3. Since the flow meter is made by putting metals and resin parts together, it must be discarded as industrial waste.</li></ul>
---	--



# Ultrasonic Flow Meter for Management of Fuel Gas

## UX/UZ Series Operation Manual

### ● Table of contents

Introduction.....	1
Confirmation of package contents .....	1
Safety concerns.....	2
1. Overview .....	1
1-1. Outline of product.....	1
1-2. Model configuration.....	1
1-3. Name of each part .....	2
1-3-1. UX .....	2
1-3-2. UZ .....	3
1-4. Dimension drawing .....	4
1-4-1. UX .....	4
1-4-2. UZ .....	5
2. Before using the product .....	6
2-1. Connection of battery .....	6
2-2. Wiring connection .....	8
2-3. Installation.....	16
3. start-up Procedure .....	20
3-1. When the power is turned on .....	20
3-1-1. Abnormal ultrasonic measurement .....	20
3-1-2. Abnormal temperature value .....	21
3-1-3. Abnormal pressure value.....	21
3-2. When operation starts.....	21
4. Operation Procedure.....	22
4-1. Display of measurement values (measurement mode).....	24
4-1-1. Conversion display .....	24
4-1-2. Display of <b>accumulated flow volume</b> .....	24
4-1-3. Display of instantaneous flow-rate, temperature, pressure .....	25
4-2. Measurement of very small flow-rate (Test mode time selection).....	26
4-3. Setting of parameters (Settings mode).....	26
5. Alarm Display .....	27
5-1. Abnormal ultrasonic measurement.....	27

5-2. Battery replacement alarm [Internal Battery Type] .....	28
5-3. Abnormal temperature value .....	29
5-4. Abnormal pressure value (conversion flow rate type) エラー! ブックマークが定義されていません。	
5-5. Abnormal compensation (actual flow rate type)エラー! ブックマークが定義されていません。	
5-6. Abnormal memory .....	30
5-7. In the case of power outage (DC type, AC type) .....	30
6. Troubleshooting.....	31
7. Specifications .....	エラー! ブックマークが定義されていません。
7-1. List .....	32
7-2. Glossary of terms used in specifications .....	34
8. Setting of parameters .....	35
8-1. Details of setting items .....	40
Warranty and after-sale service .....	49
1) Warranty period.....	49
2) Scope of warranty .....	49
3) Requesting for service .....	49
4) Points to note for long-term use .....	49

# 1.Overview

## 1-1.Outline of product

This product is an ultrasonic flow meter mainly for fuel gas and capable of measuring the flow-rate at atmospheric pressure up to 100 kPa or 500 kPa.

The flow meter is installed to pipes by screwing its taper pipe threads to the pipes or by being tightened between pipe flanges.

- Screw connection type (Taper pipe threads) applied model: UX
- Flange type applied model: UZ

In addition, the flow meter is certified according to the following standards (except 100VAC type).

EN61326-1 : 2013 table2(EMS)

EN55011:2009+A1:2010 Group 1 ClassA(EMI)

## 1-2.Model configuration

Basic model	Nominal diameter
-------------	------------------

# 1-3.Name of each part

## 1-3-1.UX

### 1) Flow meter main unit

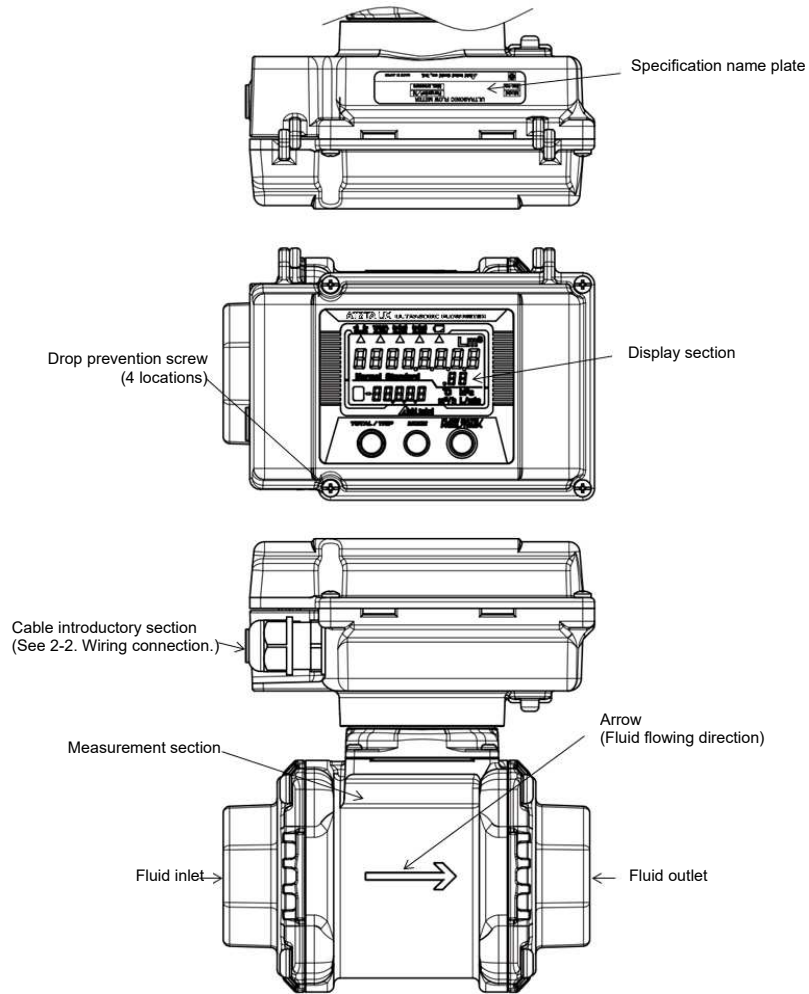

### 2) Display

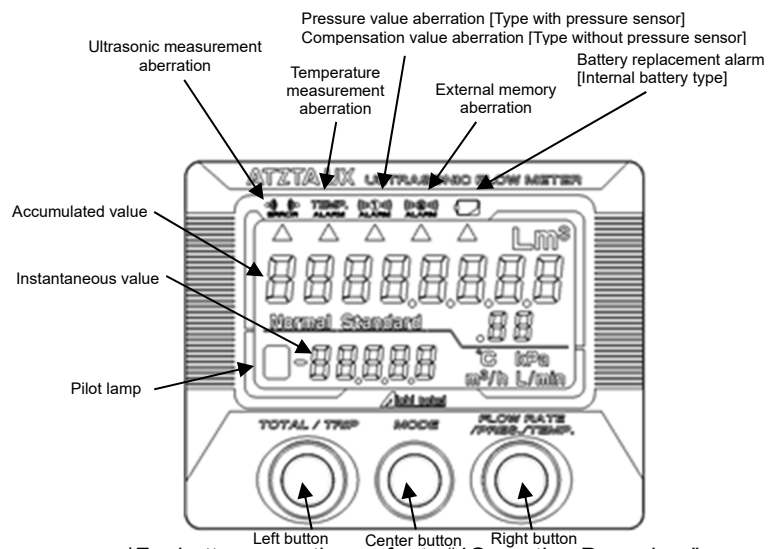

\*For button operation, refer to "4Operation Procedure".

## 1-3-2.UZ

### 3) FLOW meter main unit



### 4) DISPLAY

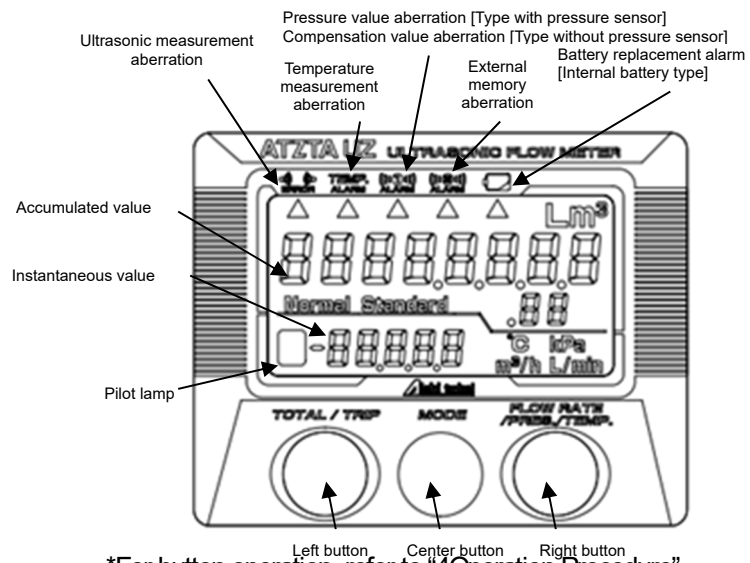

\*For button operation, refer to "4Operation Procedure".

# 1-4.Dimension drawing

## 1-4-1.UX

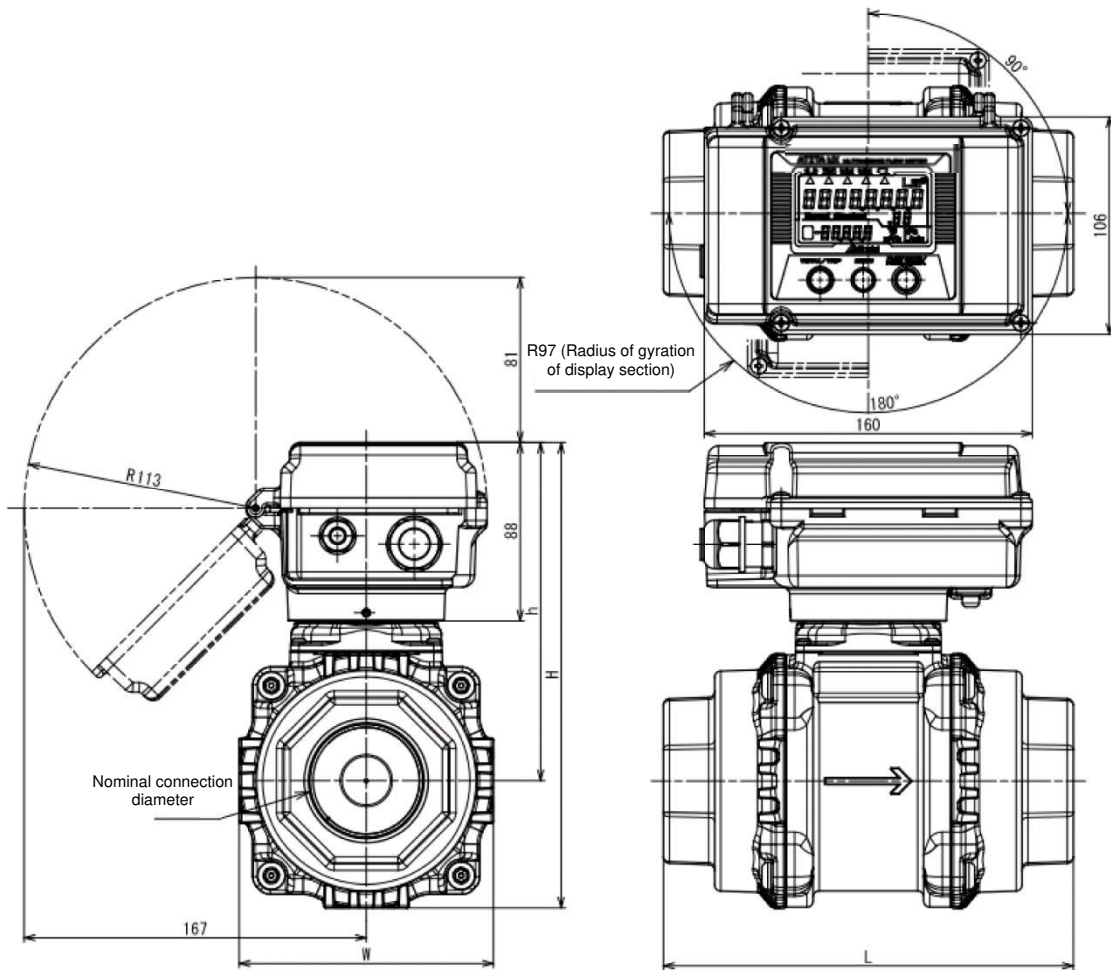

Model	Connection diameter	Size: mm			
		W	L	H	h
UX40	Rc1•1/2	108	170	211	157
UX50	Rc2	124	200	238	165

## 1-4-2.UZ

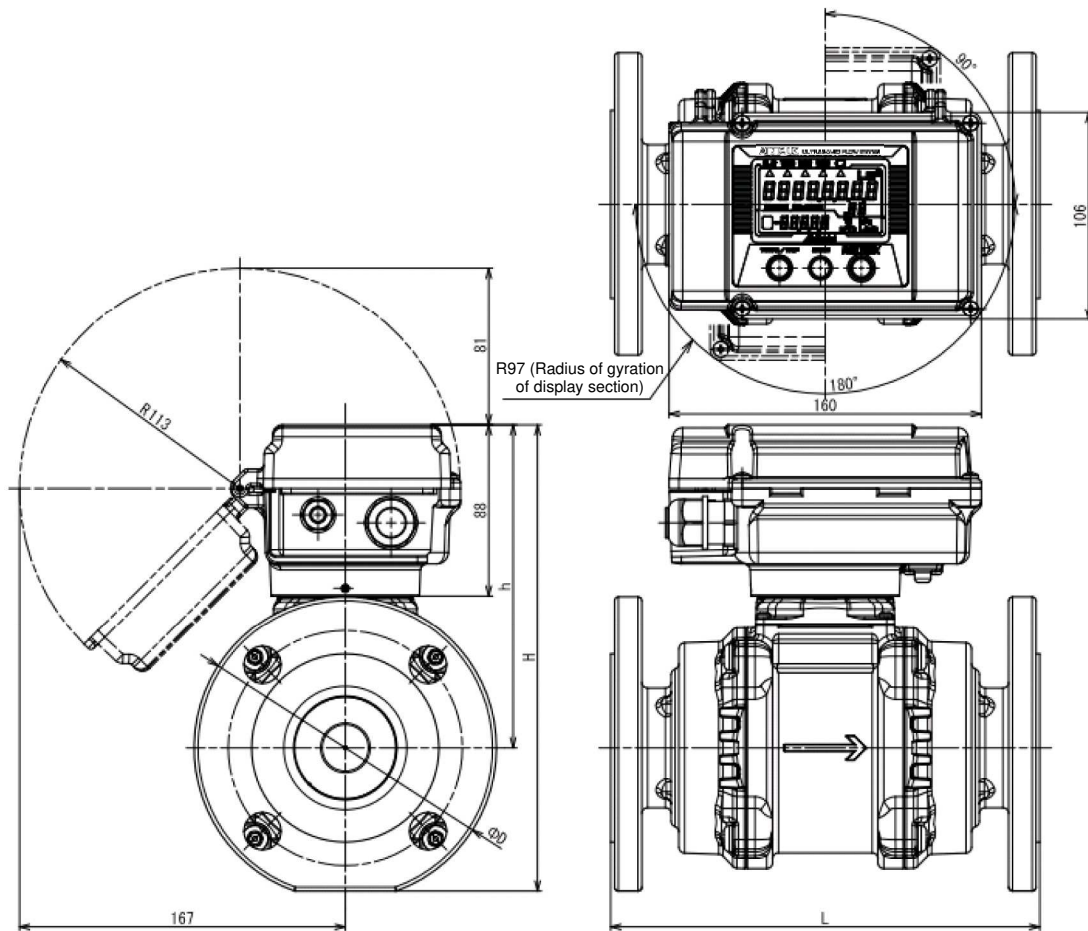

Model	Connection diameter	Size: mm			
		D	L	H	h
UZ40	JIS10K40A-RF	140	200	222	157
UZ50	JIS10K50A-RF	155	220	238	165

Use a 55-mm hex bolt to avoid interference with the display section and body.  
(Recommended bolt specification: M16 x 55 mm).

## 2. Before using the product

With this flow meter, items concerning measurement, output, and communication can be set.

At the time of purchase, the standard factory delivery settings have been made, and the user can use the flow meter as it is. Change the settings according to the usage, if needed. The settings can be changed by button operation and RS485 communication (24 VDC type and 100 VAC type only). For details, see 4.3 Setting of parameters in 4. Operation Procedure.

It is recommended to perform the settings of the flow meter prior to installation.

### 2-1. Connection of battery

In the internal battery type, the battery is not connected upon shipment. Connect the battery connectors correctly in accordance with the following procedure before using the product.

- 1) Loosen the screws at the 4 locations shown in the figure and open the cover. (The screws cannot be removed from the cover to prevent them from dropping.)

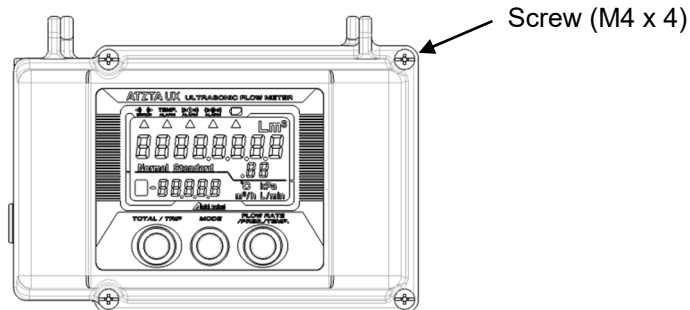

- 2) Connect the connectors of the battery and fix them to the hook of the battery pack.

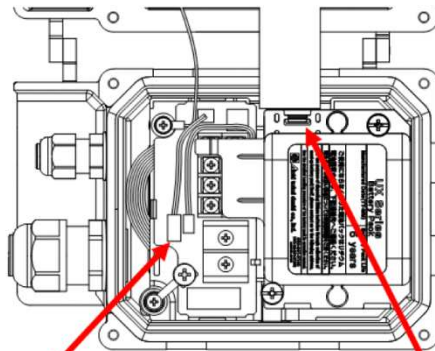

Fix the connectors to the **hook** of the battery pack.



Connect the connectors of the battery.

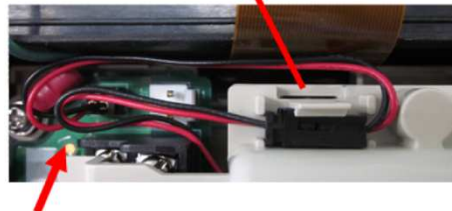

Install the lead wires as shown in the photo so that they will not be **caught** by the cover.

Note) If you use the product without fixing the connectors, it may cause a failure.



- 3) Check that the gasket fits in the gasket groove and close the cover. Close the cover carefully so that the earth wire and the lead wire of battery connector may not be caught by the cover

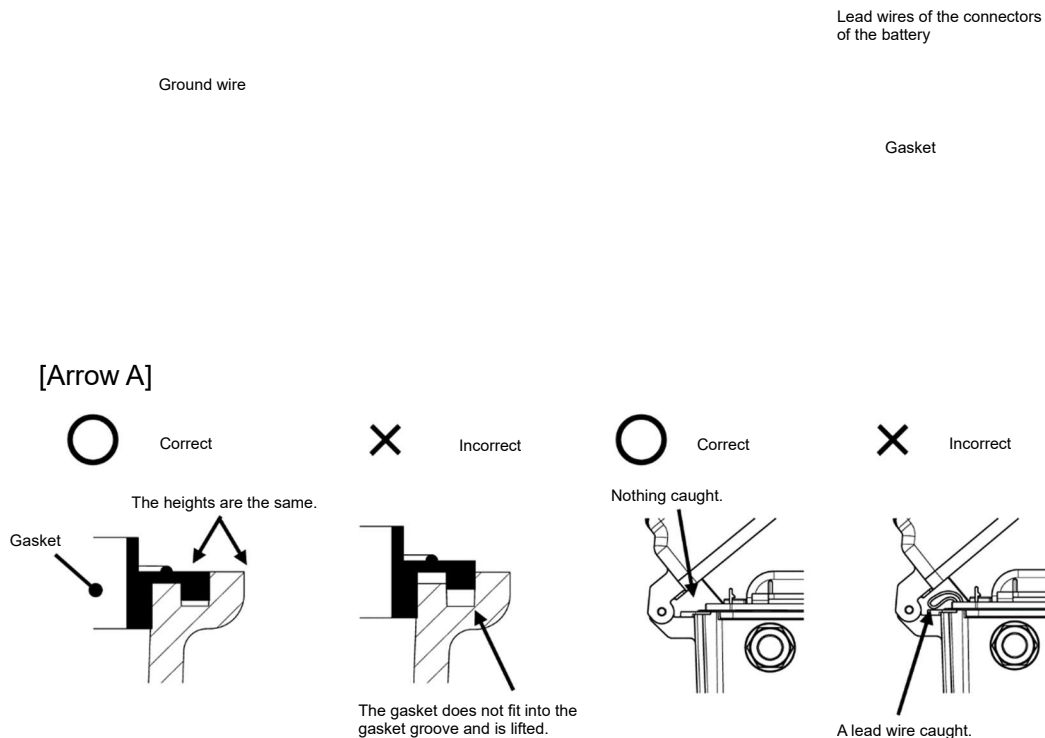

- 4) Tighten the screws at the 4 locations shown in the figure. Recommended tightening torque:  $1.0 \pm 0.1 \text{ N}\cdot\text{m}$

Note) If the screws are not tightened enough or tightened with excessive torque, it may cause entry of water and/or breakage.

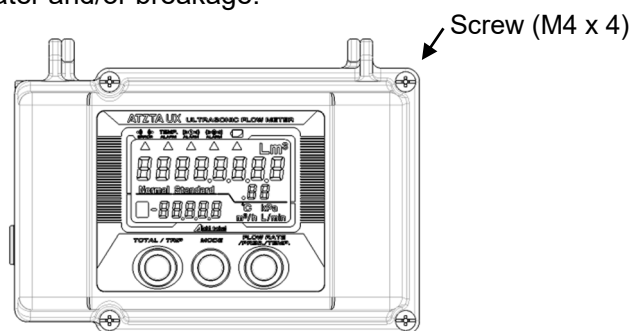

**[About battery life expectancy and replacement of battery]**

The expected life of the internal battery is 5 years. (This is the life expectancy under the standard conditions of temperature 20°C and humidity 65%RH. The actual life varies according to the installed environment (piping condition (near the governor, etc.) and temperature.)

This product contains a lithium battery, and therefore be sure not to dispose it in the general disposal route.

\*For replacement of the battery, please contact your nearest branch or sales office.

## 2-2. Wiring connection

When you connect an external output cable or connect a cable for external power input in 24 VDC type and 100 VAC type, insert each cable into the section shown in the figure in accordance with the following procedure.

The GND (signal ground) is connected to the casing.

Utilize an isolated power supply or an external connection equipment, as necessary.

Note) Perform wiring connection of an external connection device in accordance with its operation manual.

[Reference] Max. cable length: 100 m

This is the operation range under our test conditions (VCTF, 0.3 sq). The operation range may change according to the installation environment, connection device, and cable type, etc.

Note that if you use a longer cable, signals may be attenuated, and noise is easily overlaid.

### □ Procedure

- 1) Loosen the screws at the 4 locations shown in the figure and open the cover.  
The screws cannot be removed from the cover to prevent them from dropping.

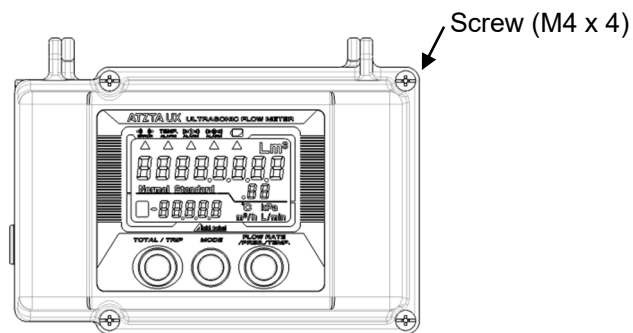

The state when the cover is opened varies according to the power supply type as shown below.

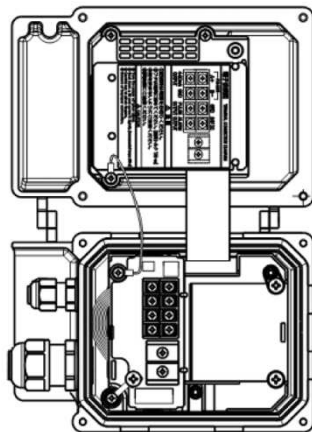

24 VDC type

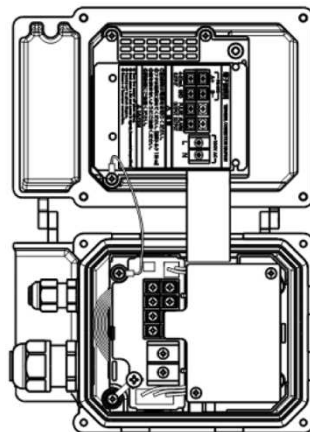

100 VAC type

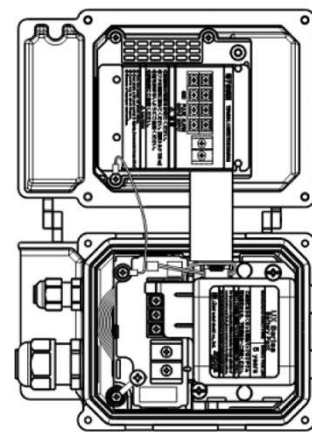

[Internal battery type]

Connect the cable.

- Procedure to connect the cable for external output  
(When you do not connect the cable for external output, The procedure (1) to (4) are not required.  
Applicable cable size:  $\phi 4$  to 6.8 mm (Example: VCTF,0.3 sq,3 to 8 cores)  
Terminal mount: M3

If you install the flow meter near an electric noise source, use a shield wire as a cable which is connected to the terminal block and ground the shield.  
Applicable cable size :  $\phi 4 \sim 6.8\text{mm}$  (MVVS 0.3sq 2-core to 6-core)

- [1] Loosen the sealing nut at the introductory part for an external output cable and pull out the pin. Be careful not to loosen the lock nut by mistake.

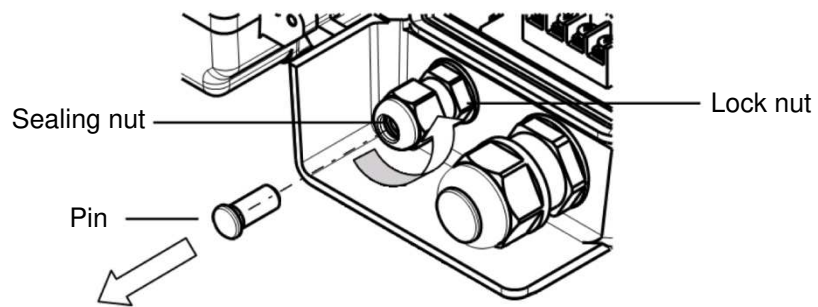

- [2] Insert the cable into the introductory part for the cable.

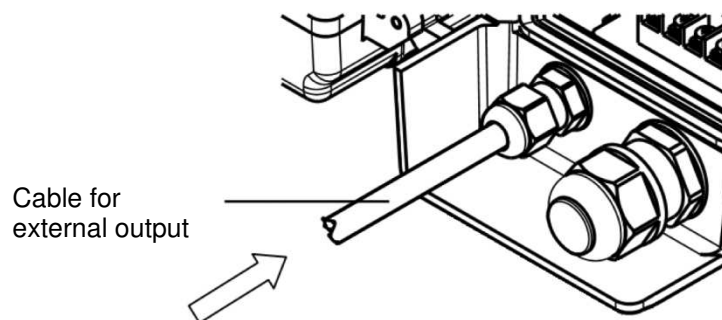

- [3] Make sure that the sheath of the cable gets into the inside of the case, crimp an applicable terminal on the cable, and connect the cable to the terminal block.

( Screw size: M3  
Recommended tightening torque:  $0.5 \pm 0.1 \text{ N}\cdot\text{m}$  )

- \* Note that incorrect wiring may cause a failure. Note that the usable terminal block varies according to the power supply type. (For the usage of each terminal mount, see “Terminal Connection Diagram” affixed inside of the cover or “Wiring Connection of Each Power Supply Type” on page 14 and 15.)

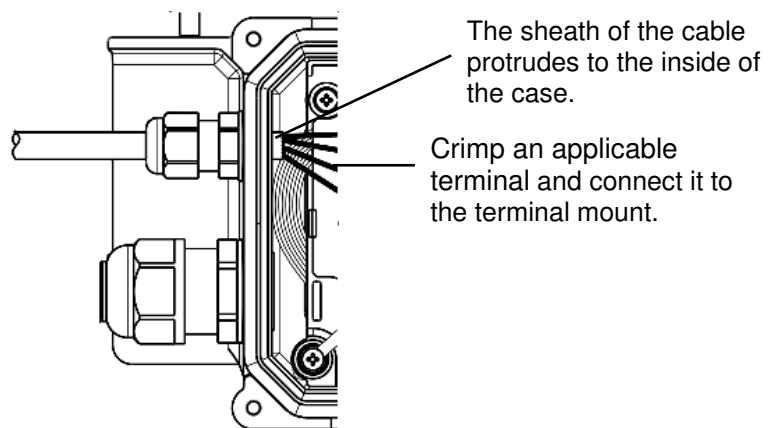

- [4] Tighten the sealing nut.  
( Recommended tightening torque:  $1.0 \pm 0.1 \text{ N}\cdot\text{m}$  )

If a torque wrench is not available, the method of tightening the nut at appropriate torque is to manually tighten the sealing nut completely, or tighten it with a tool, and when you feel load, retighten it by  $90^\circ$  (=  $1/4$  rotation). Do not tighten further. (Excessive torque may damage cables, break seal nut and cause entry of water due to seal deformation.)

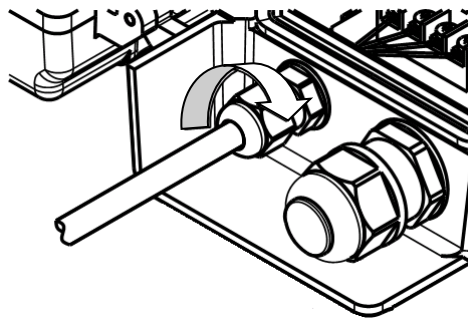

- Procedure to connect the cable for external power input  
(When you do not connect the cable for external power input, the procedure (5) to (8) are not required.)

Applicable cable size:  $\phi 6.5$  to 12.5 mm (Example: CV2sq2 core, CVV1.25sq2 core)

Terminal mount: M3 (in case of 24 VDC), M4 (in case of 100 VAC)

If you install the flow meter near an electric noise source, use a shield wire as a cable which is connected to the terminal mount and ground the shield.

- [5] Loosen the sealing nut at the introductory part for an external power input cable and remove the pin. Be careful not to loosen the lock nut by mistake.

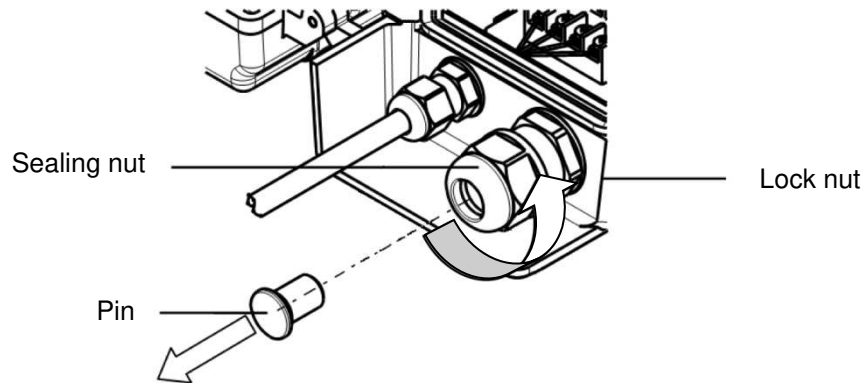

- [6] Insert the cable into the introductory part for the cable.

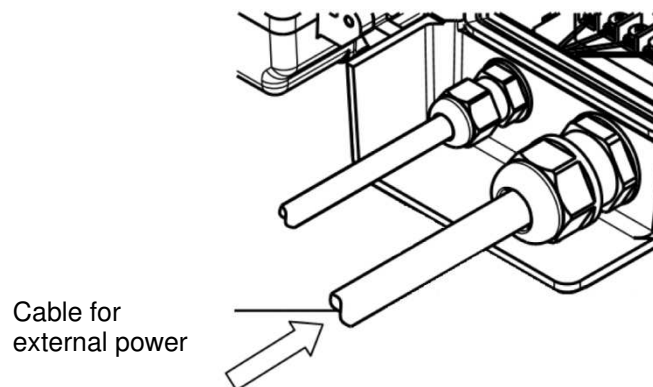

- [7] Make sure that the sheath of the cable gets into the inside of the case, crimp an applicable terminal on the cable, and connect the cable to the terminal block.

[In the case of 24 VDC type]

( Screw size: M3  
Recommended tightening torque:  $0.5 \pm 0.1 \text{ N}\cdot\text{m}$  )

[In the case of 100 VAC type]

( Screw size: M4  
Recommended tightening torque:  $1.0 \pm 0.1 \text{ N}\cdot\text{m}$  )

Note) The cover of the terminal mount is removed at the time of wiring connection. Be sure to restore it after wiring connection is finished.

- \* Note that incorrect wiring may cause a failure. Note that the usable terminal mount varies according to the power supply type. (For the usage of each terminal mount, see “Terminal Connection Diagram” affixed inside of the cover or “Wiring Connection of Each Power Supply Type” on page 14 15.)

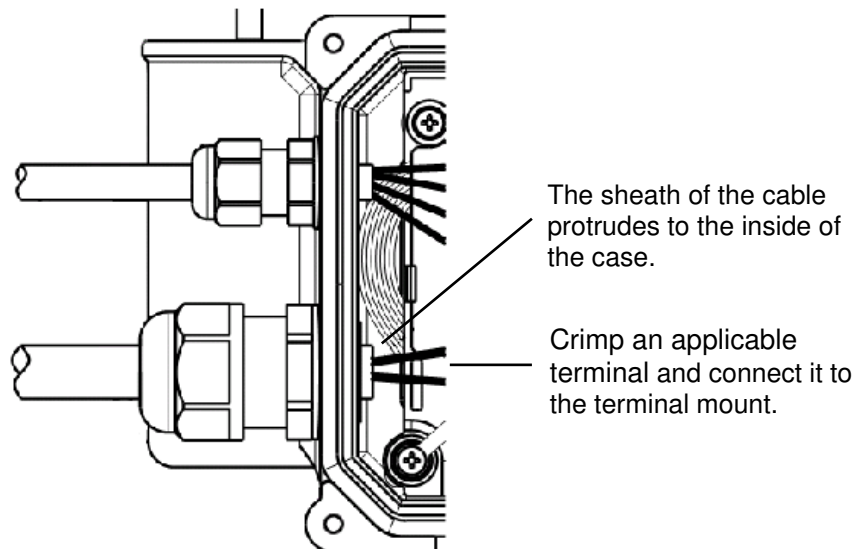

- [8] Tighten the sealing nut.  
 ( Recommended tightening torque:  $1.5 \pm 0.1 \text{ N}\cdot\text{m}$  )

If a torque wrench is not available, the method of tightening the nut at appropriate torque is to manually tighten the sealing nut completely, or tighten it with a tool, and when you feel load, retighten it by  $90^\circ$  (= 1/4 rotation). Do not tighten further. (Excessive torque may damage cables, break seal nut and cause entry of water due to seal deformation.)

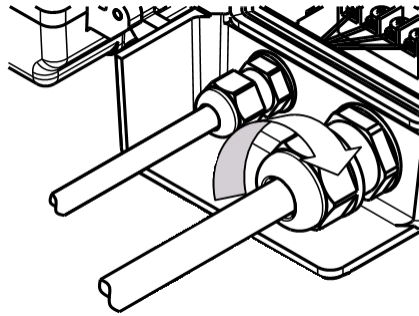

- 2) Check that the gasket fits in the gasket groove and close the cover.  
 Close the cover carefully so that the earth wire and the lead wire of battery connector may not be caught by the cover.

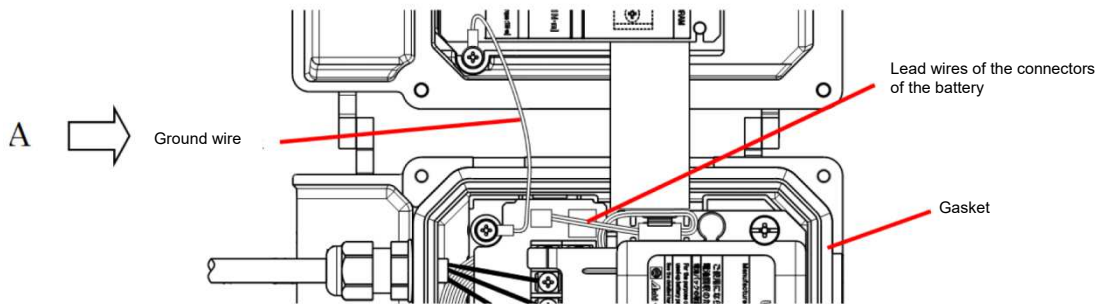

[Arrow A]

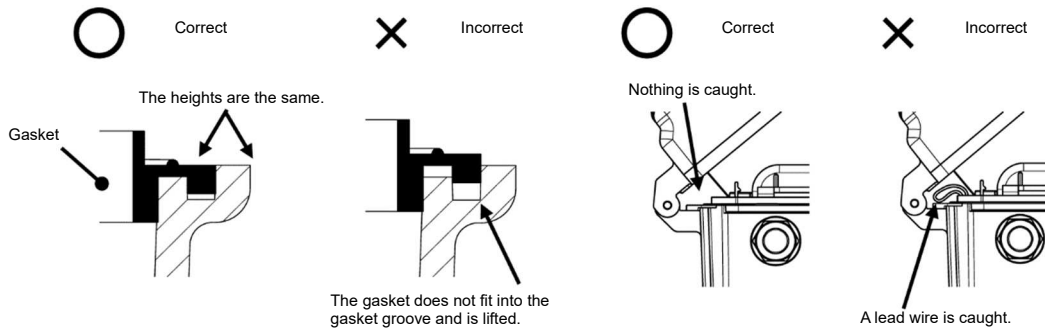

3) Tighten the screws at the 4 locations shown in the figure.

( Recommended tightening torque:  $1.0 \pm 0.1 \text{ N}\cdot\text{m}$  )

Note) If the screws are not tightened enough or tightened with excessive torque, it may cause entry of water and/or breakage.

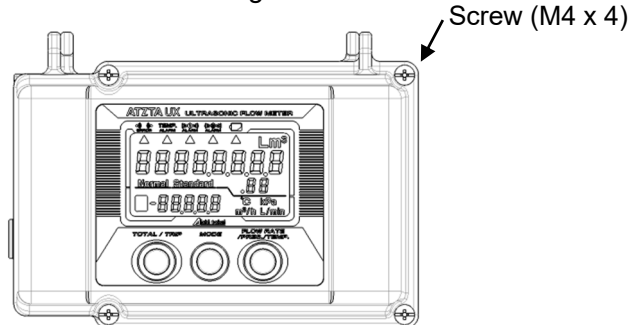

“Wiring Connection of Each Power Supply Type” is shown below.

For the usage of each terminal block, see “Terminal Connection Diagram” affixed inside of the cover.

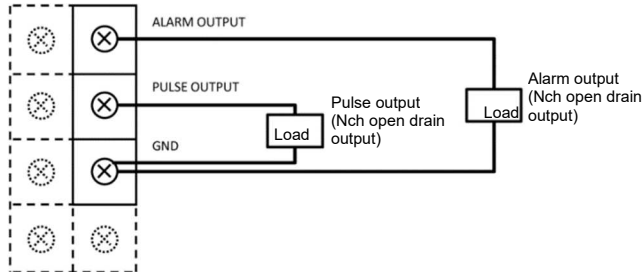
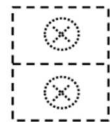

Fig.1 Wiring Connection [Internal Battery Type]

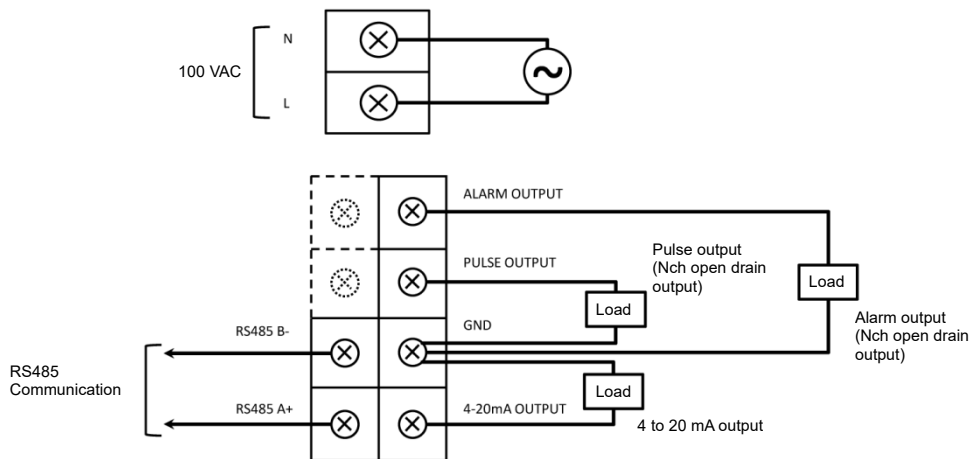

Fig 2. Wiring Connection [100 VAC Type]



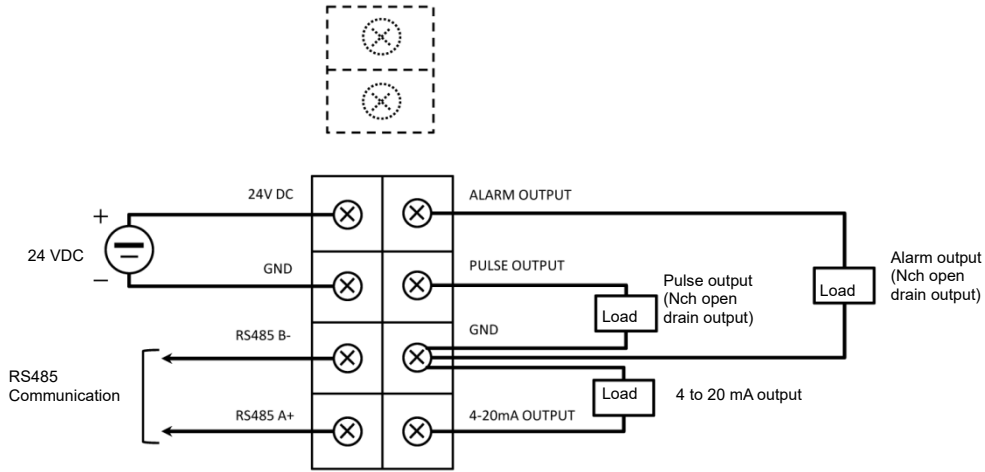

Fig.3 Wiring Connection [24 VDC Type]

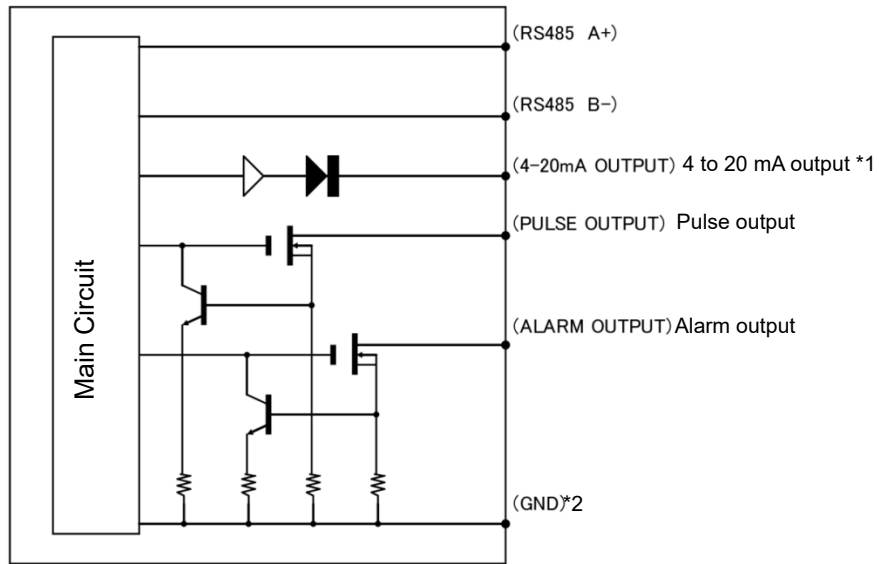

Fig.4 Input/Output Circuit Diagram

\*1 Load resistance 400 Ω or less

\*2 The GND (signal ground) is connected to the casing.

Take the following measures, as necessary.

- For DC24V type, use an insulation type power supply.
- Install a pulse isolator to isolate signals between the flow meter and a receiver.
- Use an insulating bolt, insulating washer, etc., to isolate the casing and pipes.

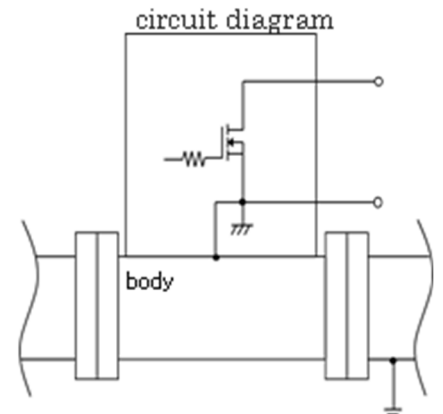

Fig. 4-2 Relationship of the casing and the GND (signal ground)  
(Example: Pulse output)

### 2-3. Installation

Match the arrow on the meter with the forward flow direction of the fluid.

This product can be installed indoors or outdoors, and on either horizontal or vertical piping. Installation in which the display part faces downward and the cable introduction part faces upward cannot be performed.

- \* It is recommended to use rising piping to install the flow meter if the air contains oil mist, dust, or other materials. If oil mist and/or dust accumulates inside this product, it may cause performance failure and/or defects.

\*

The figure below shows the recommended lengths of the straight pipe sections according to the piping condition for this flow meter. (D: Nominal diameter)

Piping condition

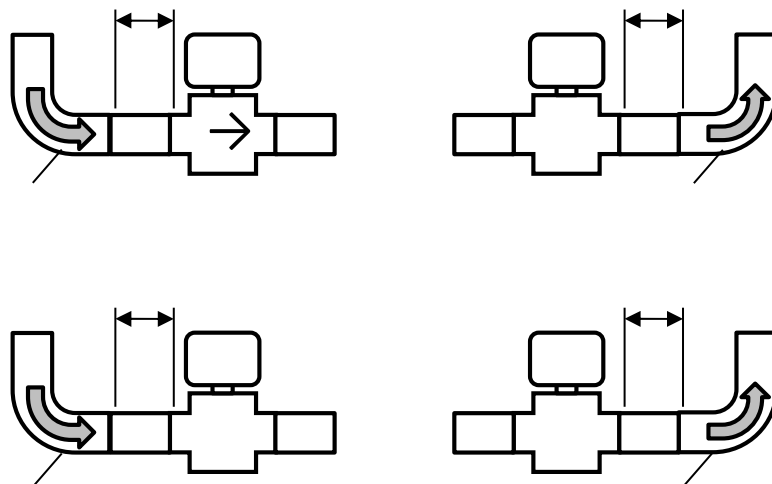

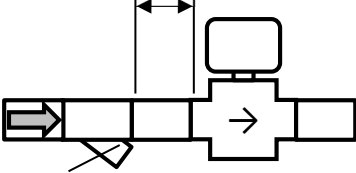
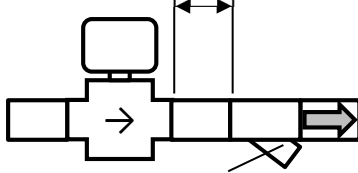
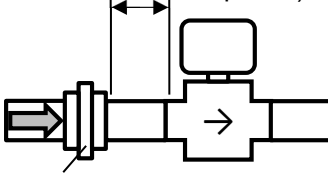
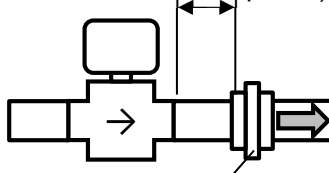
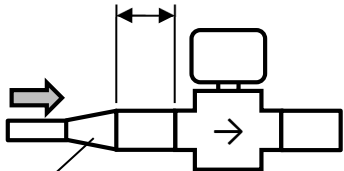
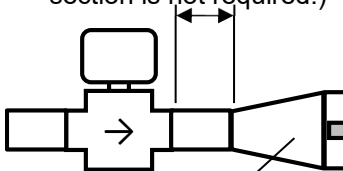
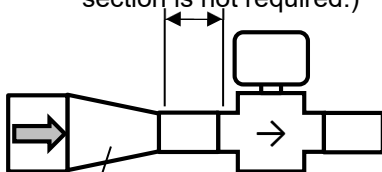
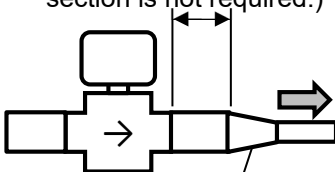
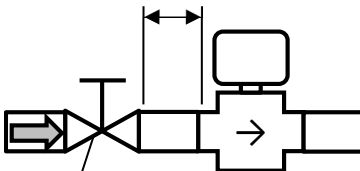
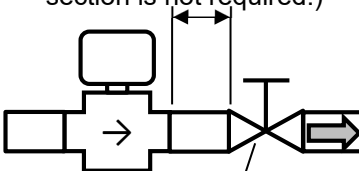
Condition	Upstream	Downstream
Y-shaped strainer	<p>0D or longer (Straight pipe section is not required.)</p>  <p>Y-shaped strainer</p>	<p>0D or longer (Straight pipe section is not required.)</p>  <p>Y-shaped strainer</p>
Union joint	<p>0D or longer (Straight pipe section is not required.)</p>  <p>Union joint</p>	<p>0D or longer (Straight pipe section is not required.)</p>  <p>Union joint</p>
Enlarge pipe (Up to 2 openings)	<p>1 opening: 0D or longer (Straight pipe section is not required.) 2 openings: 5D or longer</p>  <p>Enlarge pipe</p>	<p>0D or longer (Straight pipe section is not required.)</p>  <p>Enlarge pipe</p>
Narrowing pipe	<p>0D or longer (Straight pipe section is not required.)</p>  <p>Narrowing pipe</p>	<p>0D or longer (Straight pipe section is not required.)</p>  <p>Narrowing pipe</p>
Valve (Flow-rate is adjusted by valve.)	<p>5D or longer</p>  <p>Valve</p>	<p>0D or longer (Straight pipe section is not required.)</p>  <p>Valve</p>

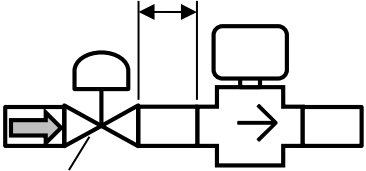
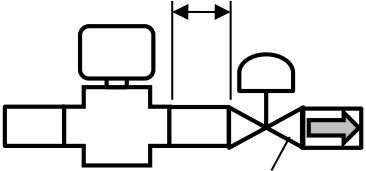
Piping condition	Upstream	Downstream
Governor		

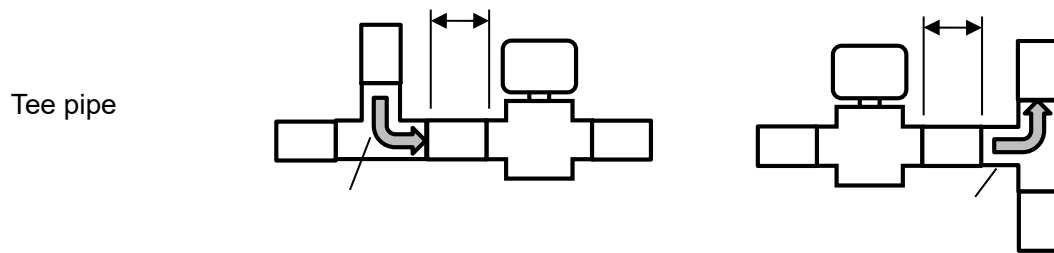

The display section can be rotated to change its orientation. To change the display's orientation, loosen the set screw at the neck section of the display using an M4 hex wrench and then rotate the display section. Once it is in the desired orientation, always make sure to tighten the set screw to fix the display section in place. When rotating the display section, do not apply a force in a direction other than the rotating direction.

When turning the display unit, do not apply force to any direction other than the rotational direction. (Applying such force may cause a failure.)

A feeling of being stuck or unsmooth rotation during the rotation is indication of possibility that force is being applied in a direction other than the direction of rotation. In the case, stop applying force once and check if force direction and the way of rotation are correct.

- \* The display section can be rotated by 180° clockwise and 90° counterclockwise in the flow direction L (left to right of the display section) as seeing from the display side. It cannot be rotated more than the rotation range.

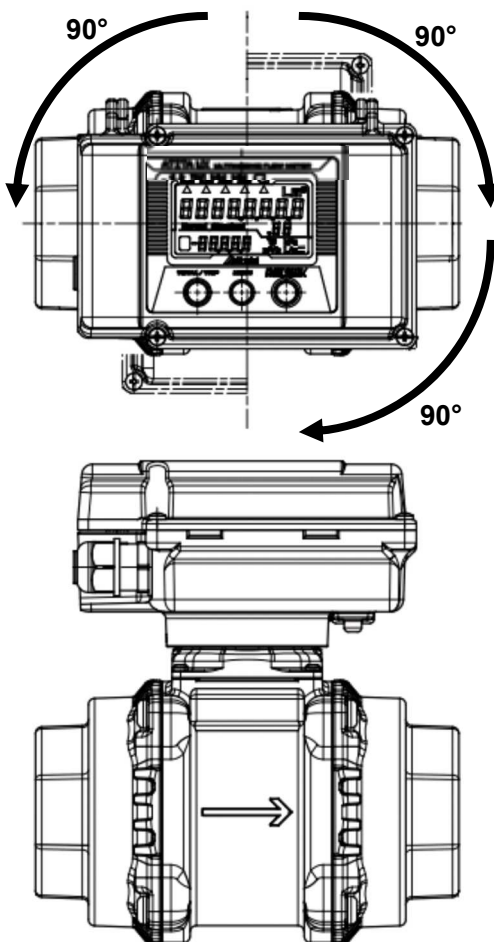

### 3.Start up procedure

After the subject fluid for measurement is set, turn on the power while no fluid flows (0 m<sup>3</sup>/h).

3-1. When the power is turned on

When the power is turned on, check that the entire LCD is turned on, and the symbols and units flicker every 2 sec.

The display is switched to the measurement mode in approx. 1 min.

If it is not switched to the measurement mode, the conceivable causes are as follows:

3-1-1. Abnormal in ultrasonic measurement

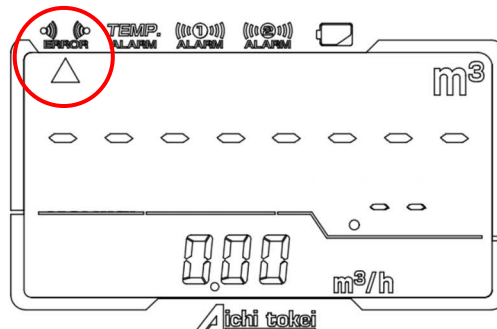

Check that there is no foreign material which prevents transmission of ultrasonic in the pipe and that oil and other fluid are not affixed and stationed in the pipe, and then turn on the power again.

When “Abnormal in ultrasonic measurement” is displayed even if no foreign material is affixed and/or stationed, please contact the company you purchased the product from or our branch or sales office.

### 3-1-2. Abnormal temperature value

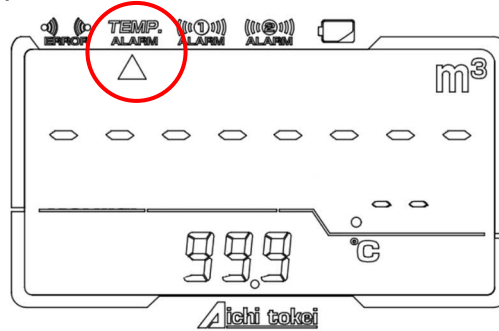

Check that the temperature in the pipe is within the specifications, and then turn on the power again. When “Abnormal temperature value” is displayed even if the temperature value is correct, please contact the company you purchased the product from or our branch or sales office.

### 3-1-3. Aberrant pressure value

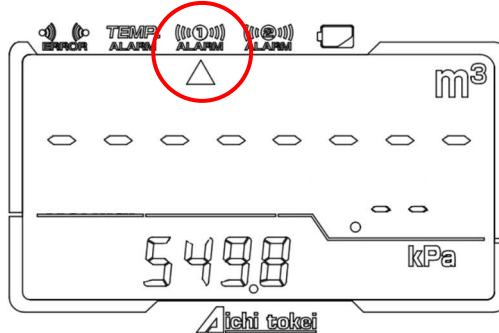

Check that the pressure in the pipe is within the specifications, and then turn on the power again. When “Aberrant pressure value” is displayed even if the pressure value is correct, please contact your nearest branch or sales office.

### 3-2. When operation starts

When you are running the meter for the first time, gradually open the valve and check that the pilot lamp is flickering. A flickering pilot lamp indicates that the fluid is flowing.

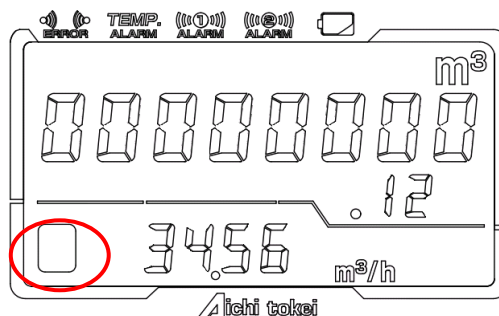

## 4. Operation Procedure

This product consists of the preliminary measurement mode, measurement mode, settings mode, and test mode.

Using the 3 buttons, you can switch the modes and displays, and make various local settings.

For arrangement of the left button, center button, and right button, see Fig 5.

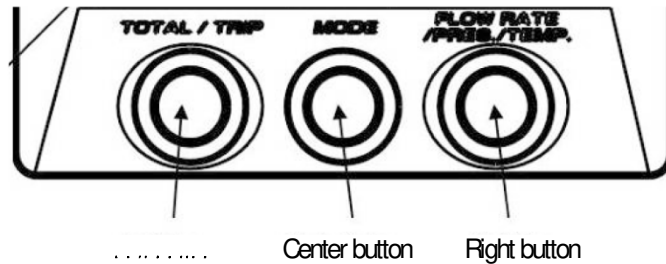

Fig 5. Button arrangement

For button operations for each operation mode, follow the table below.

Table 1 Button operation for each mode

Position and name of button		Preliminary measurement mode	Measurement mode	Setting mode		Test mode
Button position	Name			Local setting display	Detailed setting	
Left	SW1		Switchover between total <b>accumulated flow volume</b> and trip <b>accumulated flow volume</b>	Switchover to the next setting item	Switchover of setting contents Change of the flickering digit	



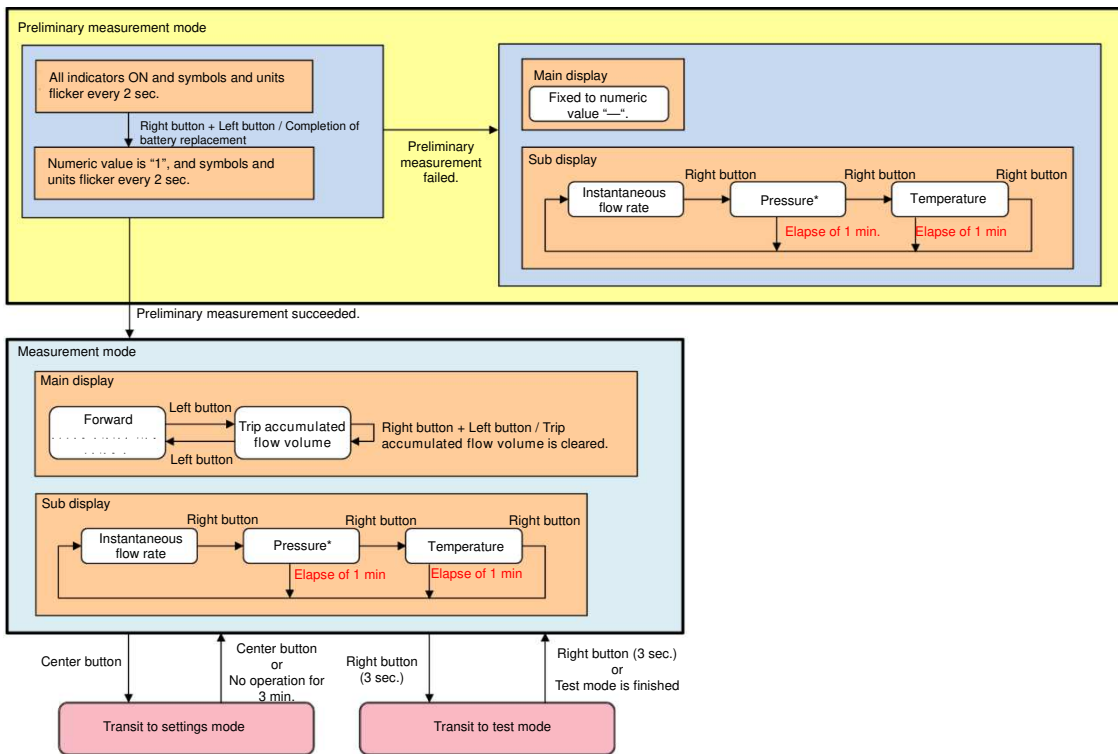

\* "Pressure" in sub display: The operating gas pressure setting value is displayed in the actual flow-rate type, and the measured pressure is displayed in the conversion flow-rate type.

Fig. 6 Button operation in measurement mode and switchover to each mode

The partition line varies according to the conversion setting.



“Without conversion”                      " With conversion  
 (Normal conversion)"                      " With conversion  
 (Standard conversion)"

#### 4-1-2.Display of **accumulated flow volume**

The number of digits displayed varies according to the conversion setting.

[Total **accumulated flow volume**] [                      . ] (m<sup>3</sup>) 8 integers and 2 decimal places

[Trip **accumulated flow volume**] [                      . ] (m<sup>3</sup>) 7 integers and 2 decimal places

Every time you press the left button, the trip **accumulated flow volume** and total **accumulated flow volume** are displayed in turn in the main display.

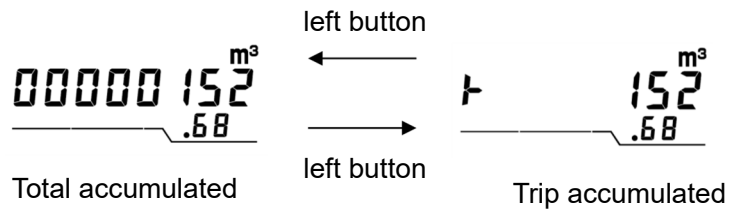

10000 152<sup>m³</sup>  
 .68

(Trip accumulated flow volume 10000152.68 [Normal·m<sup>3</sup>])

4-1-3. Display of instantaneous flow-rate, temperature, pressure

The number of the display digits of each item is shown below.

[Instantaneous Flow-rate]

(Less than 1000) [ . ] 3 integers and 2 decimal places

(1000 or more) [ . ] 4 integers and 1 decimal place

[Temperature]

[ . ] 2 integers and 1 decimal place

[Pressure]

(Type without pressure sensor) [ . ] 3 integers and 2 decimal place (The operating gas pressure setting value is displayed.)

(Type with pressure sensor) [ . ] 4 integers and 1 decimal place (The measured pressure value is displayed.)

\* The content of the pressure display is different between the type without pressure sensor and type with pressure sensor.

Type without pressure sensor: Operating gas pressure setting value (The partition line is turned off.)

Type with pressure sensor: Measurement value (The partition line is turned on.)

Every time the right button is pressed, the sub display will cycle from Pressure to Temperature and then to instantaneous flow-rate.

One minute after pressure or temperature is displayed, the display will automatically transit to the instantaneous flow-rate display.

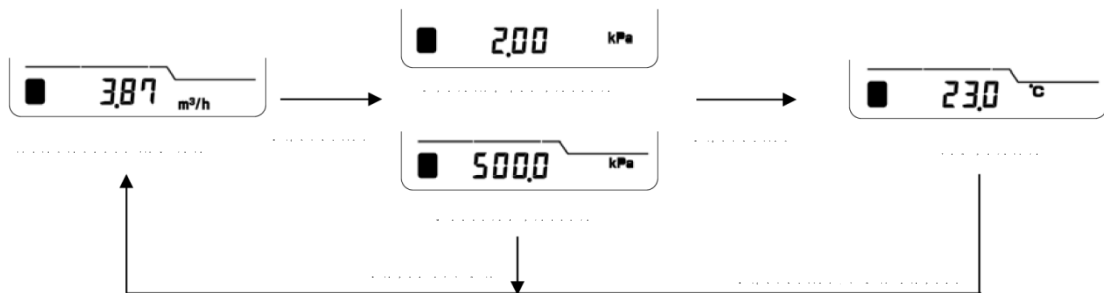

#### 4-2.Measurement of very small flow-rate (Test mode time selection)

The test mode is a function to temporarily cancel the low flow cutoff.

Please use the test mode under conditions where there is no flow.

You can transit to the test mode by pressing the right button for 3 seconds in the measurement mode, and this will allow you to measure very small flow-rates.

In the test mode, the units in the sub display ("m<sup>3</sup>/h", "kPa", "°C") flicker every 0.5 sec.

You can select 3 min, 60 min, or unlimited as the test mode time, and when the specified time elapses, the mode will automatically transit to the measurement mode. The mode will transit to the measurement mode if the right button is pressed for 3 seconds or longer again in the test mode.

If the flow-rate value in the instantaneous flow-rate display is (+) 0.01 or larger, or the pilot lamp is flickering, there is a possibility of a leakage at the downstream of the meter.

If "-" (minus) is displayed in the instantaneous flow-rate display, there is a possibility of a leakage\* at the upstream of the meter.

- \* Possibility of leakage: Please note that this is strictly a possibility as the displayed value also includes zero flow-rate offset, internal convection and other factors. The instantaneous flow-rate display in test mode is rounded off to the second decimal point.

Examples) Measurement value: 0 to 0.004 [m<sup>3</sup>/h] -> Display: 0.00 [m<sup>3</sup>/h]

Measurement value: -0.004 to 0 [m<sup>3</sup>/h] -> Display: -0.00 [m<sup>3</sup>/h]

#### 4-3.Setting of parameters (Settings mode)

Press the center button, and you will transit to the settings mode. If you press the center button again, you will transit from the settings mode to measurement mode. If no operation is performed in the settings mode for 3 minutes, the mode will automatically transit to the measurement mode.

In the settings mode, you can change the settings explained in Table 4 Setting items and settings in Settings mode (page 35).

For button operation in the settings mode, see Display Switchover Diagram in the settings mode Fig. 7 to 9 (page 46 to 48).

- \* The same settings can be made via RS485 communication. Make settings via RS485 communication under conditions where button operations may be difficult, such as when the flow meter is used at heights. Refer to communication specifications "TS-UX-002-TG" for details on the communication features.

You can download the communication specifications from our web site.

## 5.Alarm Display

In the alarm display, “▲” corresponding to the applicable alarm is turned on.

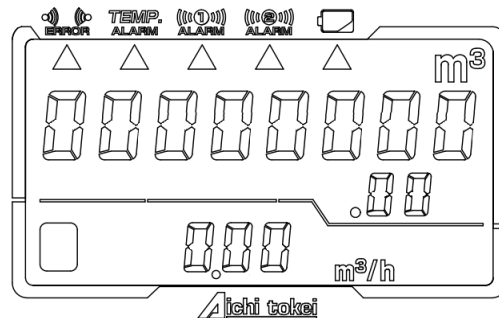

### 5-1.Abnormal ultrasonic measurement

When the ultrasonic signal is small and cannot be received, “Abnormal ultrasonic measurement” is turned on, and “0.00” is displayed as the instantaneous flow-rate value.

The accumulation stopped as the **accumulated flow volume** value just before the error occurred remains displayed, and 1 mA is output as analog output.

Check that there is no foreign material which prevents transmission of ultrasonic and/or oil and other fluid are not affixed in the pipe. When “Abnormal ultrasonic measurement” is turned on even if no foreign material is affixed and/or stationed, please contact your nearest branch or sales office.

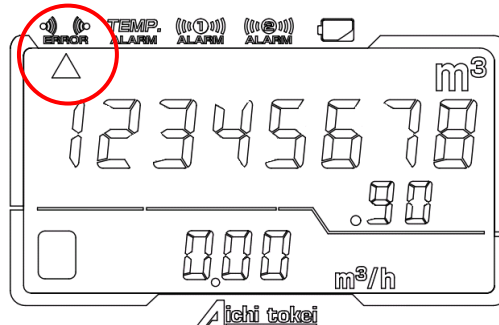

(Note) Actions when the meter is first run

At the time of installation and start of operation of the flow meter, there are cases where “Abnormal ultrasonic measurement” is turned on due to excessive flow and/or mixture of air and gas upon conversion of air into gas. After conversion is completed and the fluid is stabilized, “Abnormal ultrasonic measurement” will be turned off. (This is not an error.)

## 5-2. Battery replacement alarm [Internal Battery Type]

When 5 years pass after the battery connector is connected (the power is turned on), including storing period, “battery replacement alarm” is turned on to inform the user that it is time to replace the battery. While measurement continues even after “battery replacement alarm” is turned on, it is recommended to replace the battery as soon as possible when “battery replacement alarm” is turned on.

When you replace the battery, contact your nearest branch or sales office.

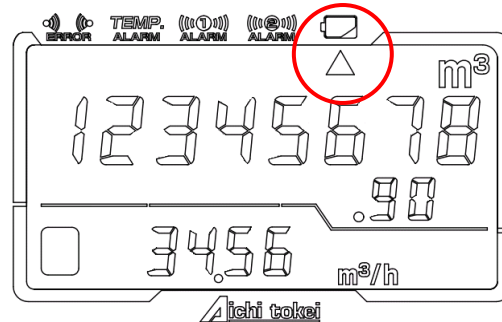

When the remaining battery becomes low after “battery replacement alarm” is turned on, the accumulated volume flickers every 0.5 sec as showing the battery is approaching to the end of life. The measurement operation is stopped, “0.00” is displayed as the instantaneous flow-rate display, and the accumulation is stopped as the **accumulated flow volume** value just before the alarm is turned on.

Replace the battery immediately.

When you replace the battery, contact your nearest branch or sales office.

The battery life is 5 years or more under the normal condition, but the end of the battery may be displayed within 5 years according to the environment temperature.

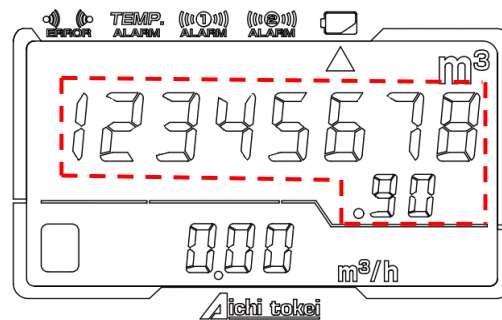

In this state, you can switch the total **accumulated flow volume** display and trip **accumulated flow volume** display using the left button, and the instantaneous flow-rate, temperature, and pressure display using the right button, but you cannot switch the mode to the settings mode using the center button.

### 5-3. Abnormal temperature value

When an error of the temperature value is detected, “Abnormal temperature value” is turned on. When an error of the temperature value is detected, “0.00” is displayed as the instantaneous flow-rate, an abnormal value is displayed as the temperature, and 1 mA is output as the analog output. As for the **accumulated flow volume** value in the main display, the accumulation process stops and the display shows the value immediately prior to the abnormality.

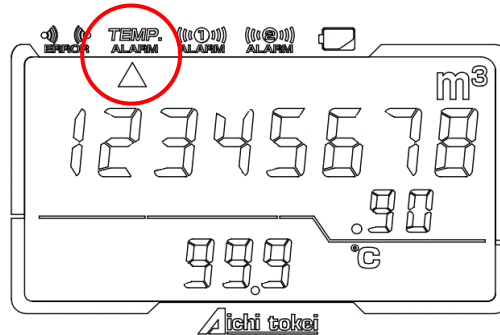

### 5-4. Abnormal pressure value (Type with pressure sensor)

When an error of the pressure value is detected, “Abnormal pressure value” is turned on. When an error of the pressure value is detected, “0.00” is displayed as the instantaneous flow-rate, an abnormal value is displayed as the pressure value, and 1 mA is output as the analog output. As for the **accumulated flow volume** value in the main display, the accumulation process stops and the display shows the value immediately prior to the abnormality.

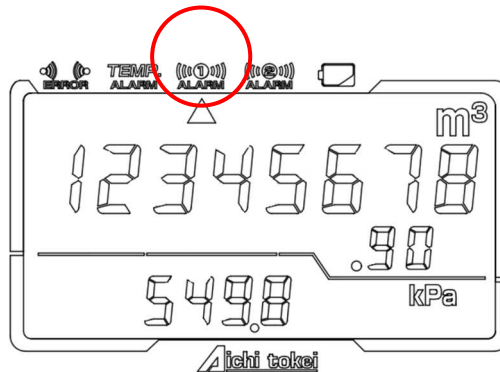

### 5-5. Abnormal compensation (Type without pressure sensor)

When an error is detected inside flow-rate compensation, “Abnormal compensation” is turned on. When an error is detected, “0.00” is displayed as the instantaneous flow-rate, and 1 mA is output as the analog output. As for the **accumulated flow volume** value in the main display, the accumulation process stops and the display shows the value immediately prior to the aberration.

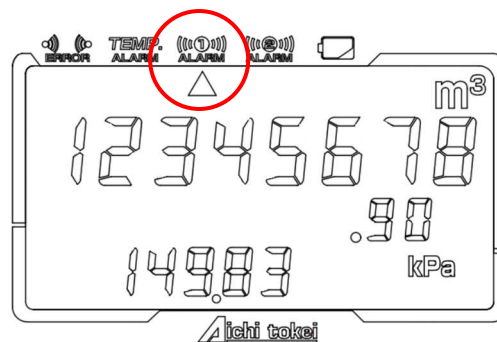

### 5-6.External memory abnormality

When abnormality data is detected upon recovery of the accumulated value when the power is turned on by setting of communication or button operation, and external power supply type (24 VDC, 100 VAC), “External memory aberration” is turned on. When “External memory abnormality” is turned on, check and reset the setting value. If “External memory abnormality” is not turned off even after all the data is reset, there is a possibility of a failure. Please contact the company you purchased the product from or our branch or sales office.

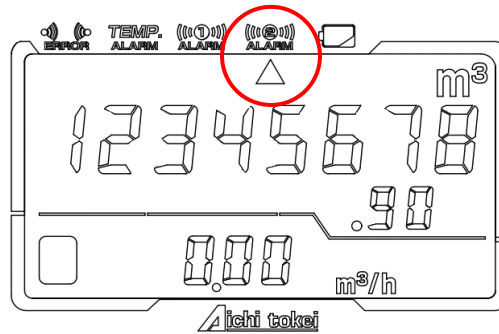

When an error of internal data is detected, the **accumulated flow volume** flickers every 0.5 sec.

There is a possibility of a failure. Please contact the company you purchased the product from or our branch or sales office

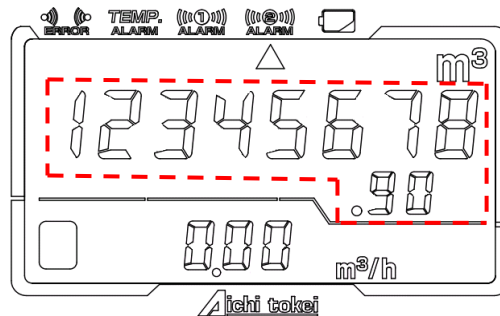

### 5-7.In the case of power outage (DC type, AC type)

- Power outage detection  
When the power supply voltage is dropped to  $18 \pm 1.1$  V or lower, the meter determines a power outage, stops the measurement, and turns off the LCD.
- Recovering from a power outage  
When the power supply voltage recovers to  $18.8 \pm 1.1$  V or greater, the meter resumes the measurement and turns on the LCD.  
The **accumulated flow volume** and trip **accumulated flow volume** are saved every 5 minutes after the power is turned on. When the flow meter recovers from a power outage, the **accumulated flow volumes** saved just before a power outage occurs are restored, and accumulation is performed using these values.  
When the flow meter recovers from a power outage, the **accumulated flow volumes** are displayed in the upper LCD.



## 6. Troubleshooting



Phenomenon

Possible cause

Remedial action



## 7.Specifications

### 7-1.List

UX [Nominal diameter] / [Pressure] [Power supply] / [Flow direction] / [Gas type]

UZ [Nominal diameter] / [Pressure] [Power supply] / [Flow direction] / [Gas type]

Model		UX40	UZ40	UX50	UZ50
Connection of pipe		Screw connection	Flange	Screw connection	Flange
		Rc1•1/2	JIS 10K	Rc2	JIS 10K
Maximum operating pressure		100 kPa	500 kPa	100 kPa	500 kPa
Gas type for measurement		City gas (13A), butane (butane 70%, propane 30%), propane (propane 98%, butane 2%), nitrogen, argon			
Power supply/ Power consumption	Battery	Dedicated lithium battery (5-year life expectancy under 20°C and 65%RH)			
	AC power supply	100 VAC $\pm$ 15% / 10 W or less (when analog output is 22 mA)			
	DC power supply	24 VDC $\pm$ 10% / 2 W or less (when voltage is 26.4 V and analog output is 22 mA)			
Flow-rate range (actual flow-rate) <sup>*1)</sup>	City gas, nitrogen, argon				

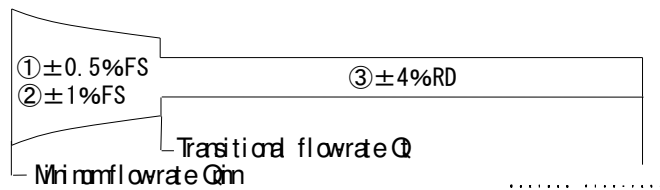

Model		UX40	UZ40	UX50	UZ50
Output	Analog	(Power-driven meter only) 4 to 20 mA DC (Load resistance 400 Ω or smaller) Select from Instantaneous flow rate, Temperature, and Pressure. Standard: Instantaneous flow rate			
	Pulse	Nch open drain output (Max. load 24 VDC, 50 mA) Output 1 (accumulated pulse): Standard: 1000L/P (Select from 10, 100, 1000, and 10000L/P.) Duty 20 to 80% Output 2 (alarm): (Power-driven) Select upper and lower limit alarm or upper limit alarm of <b>accumulated flow volume</b> . (Battery-driven) Select battery voltage decrease alarm or upper and lower limit alarm.			
	Communication <sup>*2)</sup>	(Power-driven only) Complies with RS485 Modbus/RTU. (4800 bps/9600 bps)			
Fluid temperature		-10 to +60°C			
Operating environment temperature/humidity		-10 to +60°C, 90%RH *No condensation.			
Protection structure <sup>*3)</sup>		Outdoor IP64 (JIS C 0920)			
Mass		Approx. 4.7kg	Approx. 7.0kg	Approx. 6.3kg	Approx. 8.8kg

\*1) See Table 2 and Table 3 (page 34) for the conversion flow-rate range.

\*2) For detailed specifications, download them from our web site.

\*3) If the flow meter is exposed to direct sunlight, providing a sunshade or using the optional cover is recommended.

\*4) The pressure value displayed on the LCD display is from 5 kPa.

On regarding output signal (Analog4-20mA, pulse, RS485), it outputs even 5 kPa or less.

The output interval is updated at intervals of measurement every 10 seconds for Built-in battery Model (Type B) and every 0.5 second for External power supply Model (Type D,R).

\*5) In case a distance from an elbow of minimum 10D in the upstream side and 5D in the downstream side of the meter can be secured:  $\pm 2.0\%RD$

## 7-2. Glossary of terms used in specifications

- Actual flow rate  
Cubic volume of the fluid which flows per unit of time. The actual flow rate changes depending on the temperature and pressure of fluid. The unit of fluid is m<sup>3</sup>/h.
- Normal conversion flow-rate  
The volumetric flow rate obtained by converting the temperature and pressure with which the actual flow rate is measured into 0°C and 1 atmosphere (1 atm). The unit of fluid is m<sup>3</sup>/h (Normal).
- Standard conversion flow rate  
The volumetric flow rate obtained by converting the temperature and pressure with which the actual flow rate is measured into the conversion standard temperature and conversion standard pressure. The unit of fluid is m<sup>3</sup>/h (Standard).  
The conversion standard temperature (-10 to 60°C) and conversion standard pressure (0.00 to 10.00 kPa) can be changed by buttons and communication (external power supply (24 VDC, 100 VAC) only).

Table 2 Normal conversion flow-rate values [m<sup>3</sup>/h (Normal)][Conversion example]

Pressure (kPa)		0 (atmospheric pressure)		2		10		100		500		
Temperature (°C)		0	30	0	30	0	30	0	30	0	30	
Actual flow rate (m <sup>3</sup> /h)	40A	1.6	1.60	1.44	1.63	1.47	1.76	1.58	3.18	2.86	9.50	8.56
	80	80.00	72.08	81.58	73.51	87.90	79.20	158.97	143.24	474.87	427.87	
50A	3	3.00	2.70	3.06	2.76	3.30	2.97	5.96	5.37	17.81	16.05	
	150	150.00	135.16	152.96	137.82	164.81	148.50	298.08	268.58	890.38	802.26	

Conversion standard temperature = 0°C, Conversion standard pressure = 0 kPa (gauge pressure)

Table 3 Standard conversion flow rate value [m<sup>3</sup>/h (Standard)] [Conversion example]

Pressure (kPa)	0 (atmospheric pressure)
----------------	--------------------------

### How the pressure loss characteristics

4A

5A

The pressure loss in the air is as shown in the figure on the left.

To calculate the pressure loss of each gas type, multiply the specific gravity shown below.

- City gas (13A) : 0.64
- Butane : 1.55
- Propane : 2.0
- Nitrogen : 0.97
- Argon : 1.38

## 8. Setting of parameters

It is recommended to perform the settings of the flow meter prior to installation.

On this product, setting of the items shown in Table 4 can be made by button operation and RS485 communication.

At the time of factory shipment, the standard factory delivery settings in Table 4 are set, and the user can use the flow meter as it is. Change the settings according to the usage, if needed.

For operation and setting of buttons, see 4.3 Setting of parameters in 4. Operation Procedure.

For setting by RS485 communication, see communication specifications "TS-UX-002-TG."

You can download the communication specifications from our web site.

Table 4 Setting items and settings in Settings mode

Panel Display	Corresponding setting item	Scope of setting contents	Upon factory shipment Setting contents
F01	Flow-rate conversion selection	OFF/ON	Type without pressure sensor: OFF Type with pressure sensor: ON
F02	Conversion standard temperature	-10 to 60°C	0 °C
F03	Conversion standard pressure	000.0 to 10.00 kPa	0.00 kPa
F04	Output pulse constant	10, 100, 1000, 10000 L/P	1000 L/P
F05	Operating gas pressure setting value	[UX] 0.00 to 100.00 kPa [UZ] 0.00 to 500.00 kPa	10 kPa
F06	Alarm output selection	[BT] Battery voltage decrease alarm output Flow rate upper and lower limit alarm output [DC, AC] Accumulated value upper limit alarm output Flow rate upper and lower limit alarm output	Flow rate upper and lower limit alarm output
F07	State of alarm output contact	N.O (Normally open) N.C (Normally closed)	N.O (Normally open)
F08	Alarm output lower limit	0.0 to +9999.9 m <sup>3</sup> /h	0.0 m <sup>3</sup> /h
F09	Alarm output upper limit	0.0 to +9999.9 m <sup>3</sup> /h	9999.9 m <sup>3</sup> /h
F10	Alarm output Hysteresis width	0.0 to +9999.9 m <sup>3</sup> /h	0.0 m <sup>3</sup> /h
F11	Analog output Full scale flow-rate	0.0 to +9999.9 m <sup>3</sup> /h	*See "F11" in 8-1. Details of setting items.
F12	Switchover of analog output	Instantaneous flow-rate, temperature, pressure	Instantaneous Flow-rate
F13	Communication bit rate	4800 bps, 9600 bps	9600 bps
F14	RTU address	001 to 247	001
F15	Instantaneous flow-rate moving average number of times	1 to 16 times	4 times

Panel Display	Corresponding setting item	Scope of setting contents	Upon factory shipment Setting contents
F16	Test mode time selection	3 min., 60 min., Unlimited	3 min.
F17	Gas type selection	13A, propane, butane, nitrogen, argon	*The gas type specified by the customer upon order is set.
F18	Low flow cutoff value	*See "F18" in 8-1. Details of setting items.	40A: 0.3 m <sup>3</sup> /h 50A: 0.6 m <sup>3</sup> /h
F19	Atmospheric pressure of the working environment	0.0 to 200.0 kPa	101.3 kPa
F20	Selection of with or without pressure value moving averaging	No (1 time), Yes (10 times)	Yes (10 times)
F21	With or without pressure zero-cut	"With zero-cut (ON) , Without zero-cut (OFF)	Type with pressure sensor: With zero-cut (ON)

The setting items can be divided mainly into 3 categories.

- 1) Items related to fluid
- 2) Items related to measurement and display
- 3) Items related to output

1) Setting of items related to fluid

[1] Setting related to gas type [F17]

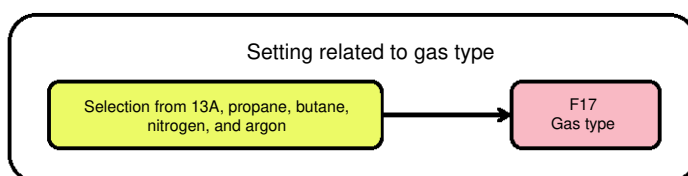

Set the gas type to be used. Since the gas type specified upon order is set at the time of factory shipment, there is no need to change this setting.

“Air” displayed in the selection window is designed for maintenance, and therefore you cannot select it for normal use.

[2] Setting related to pressure [F5] (Available only for actual flow-rate type)

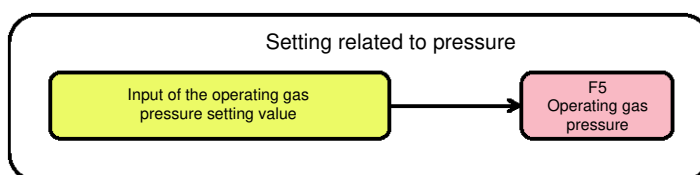

Set the pressure value of the environment in gauge pressure.

Example) When the pressure value of the environment is 2.00 kPa in gauge pressure: Setting value in [F5] “2.00”

## 2) Setting of items related to measurement and display

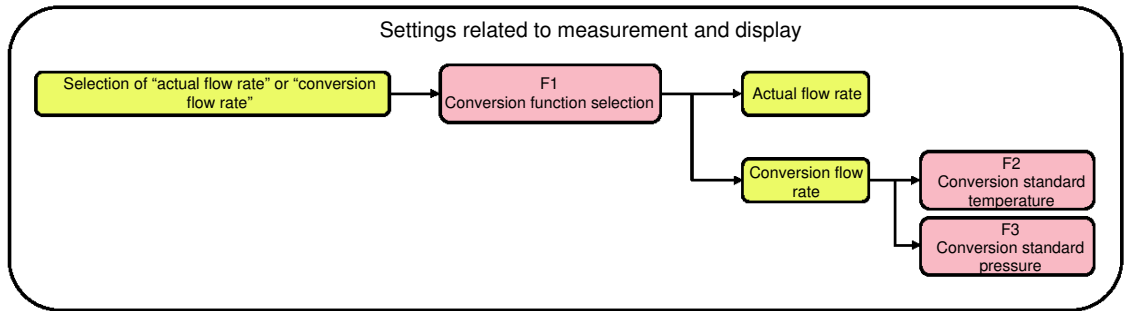

### [1] Setting of conversion function selection [F1] (Available only for conversion flow-rate type)

Set "Actual flow-rate" or "Conversion flow-rate". When "Conversion flow rate" is selected, the accumulation display, instantaneous display, and output signal correspond to the **converted flow volume** based on the settings of [F2] and [F3].

When the setting of [F1] Flow-rate conversion selection is changed, the setting value of [F4] Output pulse constant is automatically changed to 1000 [L/P]. After setting [F1], set [F4] again according to need.

### [2] Setting of conversion standard temperature [F2] and setting of conversion standard pressure [F3]

When you select "Conversion flow rate" in [F1], set the standard temperature and pressure to be used for conversion. When 0°C is set to the conversion standard temperature, and 0.0 kPa is set to the conversion standard pressure, the conversion flow-rate becomes normal conversion flow-rate. When any value other than 0°C is set to the conversion standard temperature, and any value other than 0.0 kPa is set to the conversion standard pressure, the conversion flow-rate becomes standard conversion flow-rate.

When you select "Actual flow rate" in [F1], the settings of the standard temperature and pressure to be used for conversion become invalid.

### 3) Setting of items related to output

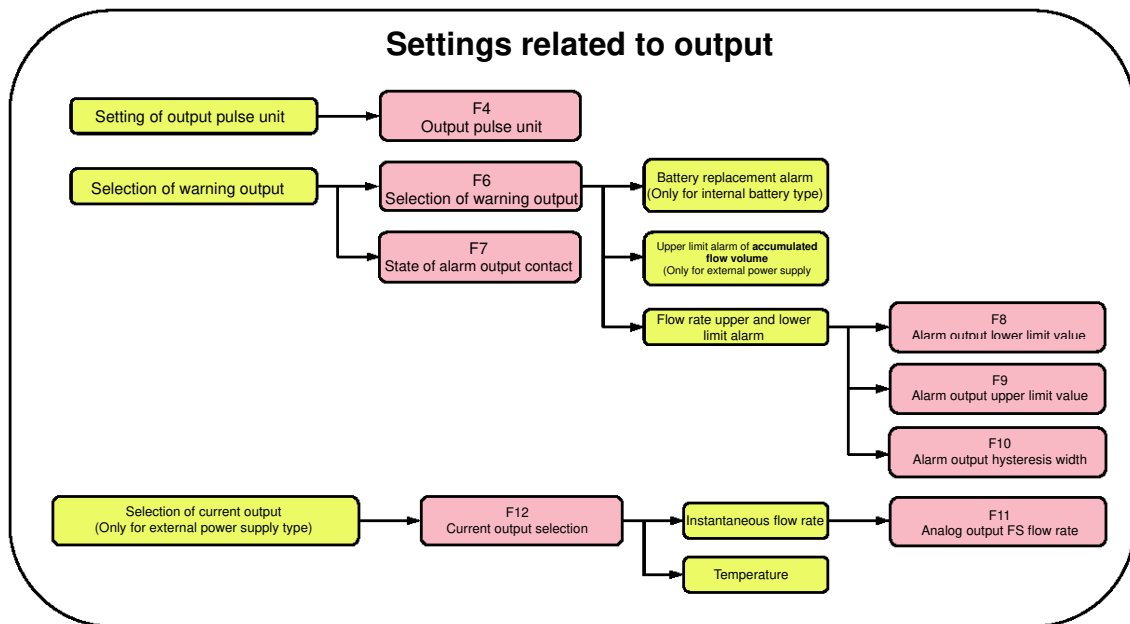

#### [3] Setting of output pulse constant [F4]

When you use pulse output, set the output pulse constant according to the usage in advance.

#### [4] Setting of alarm output selection [F6]

The selectable alarm output items vary according to the power supply type as shown below:

Internal battery type

: Flow rate upper/lower limit alarm  
or battery replacement alarm

External power supply type (24 VDC, 100 VAC): Flow rate upper/lower limit alarm or upper limit alarm of **accumulated flow volume**

Flow rate upper/lower limit alarm can be output and stopped at any flow-rate value. When you select this function, set the alarm output lower limit value [F8], alarm output upper limit value [F9], and alarm output hysteresis width [F10].



[5] Analog output selection [F12]

As the analog output type, you can select instantaneous flow-rate, temperature, or pressure according to the usage.

When you select instantaneous flow-rate, current based on the maximum flow-rate value setting of analog output is output.

When you select temperature, 4 mA is output at -10°C, and 20 mA is output at +60°C.

You can select pressure only for the conversion flow-rate type. The currents shown below are output according to the model.

[UX]: 4 mA at 0 kPa, 20 mA at 100 kPa

[UZ]: 4 mA at 0 kPa, 20 mA at 500 kPa

Setting of maximum flow-rate value of analog output (Analog output FS flow-rate) [F11]

When you use analog output for instantaneous flow-rate, it is recommended to set the full scale flow-rate (FS flow-rate) of analog output based on the maximum flow-rate. It is recommended to set a numeric value with margin as the setting value of the FS flow-rate.

For reference, a conversion example is shown in Table 2 and Table 3 (page 34).

## 8-1.Details of setting items

The items with \*1 to \*3 are displayed only for the corresponding models shown below and not displayed for other models.

- \*1 Type with pressure sensor only
- \*2 Type without pressure sensor only
- \*3 DC type and AC type only
- [F1] About flow-rate conversion selection (\*1)  
As the flow-rate conversion, you can select the actual flow-rate, normal conversion flow-rate, or standard conversion flow-rate.  
You can select the actual flow-rate, normal conversion flow-rate, or standard conversion flow-rate using the settings of [F1] Flow-rate conversion selection, [F2] Conversion standard temperature, and [F3] Conversion standard pressure. (See Table 5.)

Table 5 Display/output values based on [F1] to [F3] settings

[F1] Flow-rate conversion selection	[F2] Conversion standard temperature, [F3] Conversion standard pressure	Flow rate
No	-	Actual flow rate
Yes	0°C and 0.00 kPa	Normal conversion flow-rate
	Other than "0°C and 0.00 kPa"	Standard conversion flow rate

If you select "Yes" for conversion, the "Normal" or "Standard" lamp above the partition line will flash, and the **accumulated flow volume** display, instantaneous flow-rate display, and output signal will all correspond to the **converted flow volume**.

If you select "No" for conversion, the "Normal" or "Standard" lamp above the partition line will be turned OFF, and the **accumulated flow volume** display, instantaneous flow-rate display, and output signal will all correspond to the actual flow-rate.

When flow-rate conversion selection is set (and even if the setting is not changed), the output pulse constant is automatically changed to 1000 [L/P], which is set at the time of factory setting.

Example: When "No" is changed to "Yes"

Output pulse constant 10 L/P, No conversion

↓ "Yes" is selected.

Output pulse constant 1000 L/P, Normal flow-rate or Standard flow-rate

Conversion is internally calculated as shown below.

$$Q_n = (T + t_0) / (T + t_1) \times (P + p_1) / (P + p_0) \times Q_r$$

$Q_r$  : Actual flow-rate [m<sup>3</sup>/h]

$Q_n$  : Conversion flow-rate [Normal (Standard)•m<sup>3</sup>/h]

$T$  : 273.15 [K] (Absolute temperature of 0°C)

$t_1$  : measured temperature [°C]

$t_0$  : Conversion standard temperature [°C] (Set in Settings mode [F2])

$P$  : 101.33 [kPa abs] (Absolute pressure of 1 atm)

$p_0$  : Conversion standard pressure (Set in Settings mode [F3])

$p_1$  : measured pressure value (gauge pressure) [kPa]

When you use both the external output function and conversion flow-rate, it is recommended to set the output constant in reference to the conversion example Table 2 and Table 3 (page 34).

- [F2] Conversion standard temperature (\*1)  
When you select “Conversion flow rate” in [F1] Conversion function selection, set the temperature to be used as the standard for conversion.  
The value can be set within the range of -10°C to 60°C in 1°C steps.  
When you select “Actual flow rate”, the setting of the conversion standard temperature becomes invalid.
- [F3] Conversion standard pressure (\*1)  
When you select “Conversion flow rate” in [F1] Conversion function selection, set the pressure to be used as the standard for conversion.  
When you select “Actual flow rate”, the setting of the conversion standard pressure becomes invalid.
- [F4] About output pulse constant  
Select the output pulse constant from “10000”, “1000”, “100”, and “10”.  
(Unit is [L/P].)  
This setting may not be available depending on the combination of the model and flow-rate conversion selection.  
An option indicating that the item cannot be selected is not displayed. (See Table 6.)

Table 6 Output pulse constant

	Nominal diameter	Pressure sensor	Conversion	Output pulse constant [L/P]			
				10	100	1000	10000
UX	40	0	/	○	○	○	○
			OFF	○	○	○	○
		ON	○	○	○	○	
	50	0	/	○	○	○	○
			OFF	○	○	○	○
		ON	■	○	○	○	
UZ	40	0	/	○	○	○	○
			OFF	○	○	○	○
		ON	■	○	○	○	
	50	0	/	○	○	○	○
			OFF	○	○	○	○
		ON	■	○	○	○	

○ Selectable      ■ Not selectable

When the setting of [F1] Conversion function selection is changed, the setting value of [F4] Output pulse constant is automatically changed to 1000 [L/P]. After setting [F1], set [F4] again according to need.

- [F5] About operating gas pressure setting value (\*2)  
Set the pressure value of the environment in gauge pressure.  
Set the value in the range of [UX] 0 to 100.00 [kPa] and [UZ] 0 to 500.00 [kPa] in increments of 0.01 [kPa].
- [F6] About alarm output selection  
The selectable alarm output items vary according to the power supply type as shown below:  
Internal battery type : Flow rate upper/lower limit alarm or battery replacement alarm  
External power supply type (24 VDC, 100 VAC) : Flow rate upper/lower limit alarm or upper limit alarm of **accumulated flow volume**

<Flow rate upper and lower limit alarm output>

In alarm output, an alarm signal is output when the instantaneous flow-rate exceeds the alarm output upper limit value or it becomes lower than the alarm output lower limit value. An alarm signal is stopped when the instantaneous flow-rate exceeds the (alarm output lower limit value + alarm output hysteresis width) or it becomes lower than the (alarm output upper limit value - alarm output hysteresis width) while an alarm is output.

Make the setting in a way that the (alarm output upper limit value) > (alarm output lower limit value + alarm output hysteresis width).

<Battery replacement alarm>

When 5 years pass after the battery connector is connected (the power is turned on), an alarm signal is output as the time to replace the battery.

<Upper limit alarm of **accumulated flow volume**>

When the **accumulated flow volume** for 1 hour after the power is turned on becomes higher than the specified **accumulated flow volume**, an alarm signal is output, and that state is kept for 1 hour.

When a message to reset the accumulated value upper limit alarm is received through communication, the alarm output is stopped, but observation of the accumulated value per hour continues.

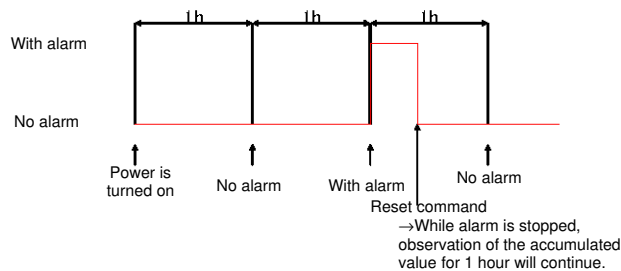

The upper value of the **accumulated flow volume** is set via communication.

\*For detailed communication specifications, download them from our web site.

- [F7] About state of alarm output contact  
As the state of the alarm output contact, select either "Normally open (n. OP)" or "Normally closed (n. CL)."  
Set this to "Normally open" in case of using a battery-powered signal receiving device.
- [F8] About alarm output lower limit  
Set the flow-rate value at the lower limit side of the upper/lower limit flow-rate alarm output. When it is used by "conversion flow-rate", set the conversion value.
- [F9] About alarm output upper limit  
Set the flow-rate value at the upper limit side of the upper/lower limit flow-rate alarm output. When it is used by "conversion flow-rate", set the conversion value.
- [F10] About hysteresis width for alarm output  
With regard to the flow-rate value defined for the upper and lower limits of the upper/lower limit flow-rate alarm output, set the flow-rate range to stop the alarm output. When it is used by "conversion flow-rate", set the conversion value.  
For instance, when the upper limit of the flow-rate is set to 7.00 [m<sup>3</sup>/h], the lower limit of the flow-rate is set to 2.00 [m<sup>3</sup>/h], and alarm output hysteresis width is set to 1.00 [m<sup>3</sup>/h], an alarm is output when the flow rate exceeds 7.00 [m<sup>3</sup>/h], and the alarm stops when the flow rate becomes lower than 6.00 [m<sup>3</sup>/h] at the upper limit side. Likewise, at the lower limit side, an alarm is output when the flow rate becomes lower than 2.00 [m<sup>3</sup>/h], and the alarm stops when the flow rate becomes larger than 3.00 [m<sup>3</sup>/h].
- [F11] About full scale flow-rate for analog output (\*3)  
Set the full scale flow-rate value when the instantaneous flow-rate is set for analog output. When you use analog output for the conversion flow rate, set the converted full scale flow-rate.

The flow rate values shown below are set at the time of factory shipment.

	[Nominal diameter]	[Pressure]	Full scale flow-rate value [m <sup>3</sup> /h]
UX	40A	0	80
		100	300
	50A	0	150
		100	600
UZ	40A	0	80
		500	700
	50A	0	150
		500	1300

- [F12] About analog output selection (\*3)  
Select the output signal of analog output from "Instantaneous flow-rate (FLo)", "Temperature (tEP)", and "Pressure (PrS)".  
Note that "Pressure" can be selected only for the conversion flow-rate type.  
("Pressure" is not displayed for the actual flow-rate type.)
- [F13] About communication bit rate (\*3)  
Select either 4800 bps (4800)" or "9600 bps (9600)" for your communication bit rate.
- [F14] About RTU address (\*3)  
Select a value between 001 to 247 for the RTU address.
- [F15] About moving average number of times  
Select the moving average number of times for display and output of the instantaneous flow-rate. The moving average number of times is set to 4 times upon factory shipment, and the immediate 4 measurement values are adopted.  
While there is no need to change the moving average number of times under normal usage, you can select 1 to 16 times. When you select 1 time, "no moving average" is set.
- [F16] About test mode time selection  
You can select the test mode time. At the time of factory shipment, "3 min. (3)" is set.  
You can select "60 min. (60)" and "Unlimited (--)" in addition to 3 min.
- [F17] Gas type selection  
Select the gas type to be measured from "13 A (13A)" "Propane (Pro)", "Butane (but)", "Nitrogen (n2)", and "Argon (Ar)".  
"Air" displayed in the selection window is designed for maintenance, and therefore you cannot select it for normal use.  
Since the gas type specified upon order is set at the time of factory shipment, there is no need to change this setting under normal use.
- [F18] Low flow cutoff value  
Set the low flow cutoff value where the instantaneous flow-rate is 0 m<sup>3</sup>/h.  
The settable range is defined as  $0 \leq \text{Low flow cutoff value} < Q$  (See Table 7).  
When you use this value for the conversion flow-rate, set the conversion value.

Table 7 Upper limit of low flow cutoff value

Model	Flow-rate Q [m <sup>3</sup> /h]
UX40	6.00
UX50	20.00
UZ40	20.00
UZ50	30.00

- [F19] Atmospheric pressure of the working environment  
Set the atmospheric pressure of the working environment in absolute pressure [kPa]. At the time of factory shipment, 101.3 [kPa] is set.  
There is no need to change this setting under normal use. However, if the setting value at the time of factory shipment is used at a high altitude place, error in accuracy occurs when calculating the conversion flow-rate.  
The relationship between the altitude, atmospheric pressure, and maximum error in accuracy is shown in Table 8. (Reference value)

Table 8 Atmospheric pressure of the working environment

Altitude (m)	Atmospheric pressure (absolute pressure) (kPa)	Max. error in accuracy (%) (Atmospheric pressure of the working environment: 101.3 kPa Measured pressure value: 0 kPa (gauge pressure))
0	101.3	±0.0
200	98.95	+2.4
400	96.61	+4.9
1000	89.87	+12.7

- [F20] Selection of with or without pressure value moving averaging (\*1)  
Select either "With averaging (10)" or "No averaging (1)" for pressure values.  
If "With averaging" is selected, the moving average value of the 10 most recently measured pressures is used for display and output.
- [F21] With or without pressure zero-cut (\*1)  
Select "With zero-cut (on)" or "Without zero-cut (oFF)" for zero-cut of pressure value.  
If "With zero-cut (on)" is selected, in the case that the measured pressure value is 5[kPa] or less, the pressure value is indicated and outputted as 0[kPa]. In the case the setting of "pressure value averaging" is "With averaging", zero-cut judgment is to be done based on the pressure value of moving average after such averaging.

A diagram showing the display changeover in each setting mode is given below.

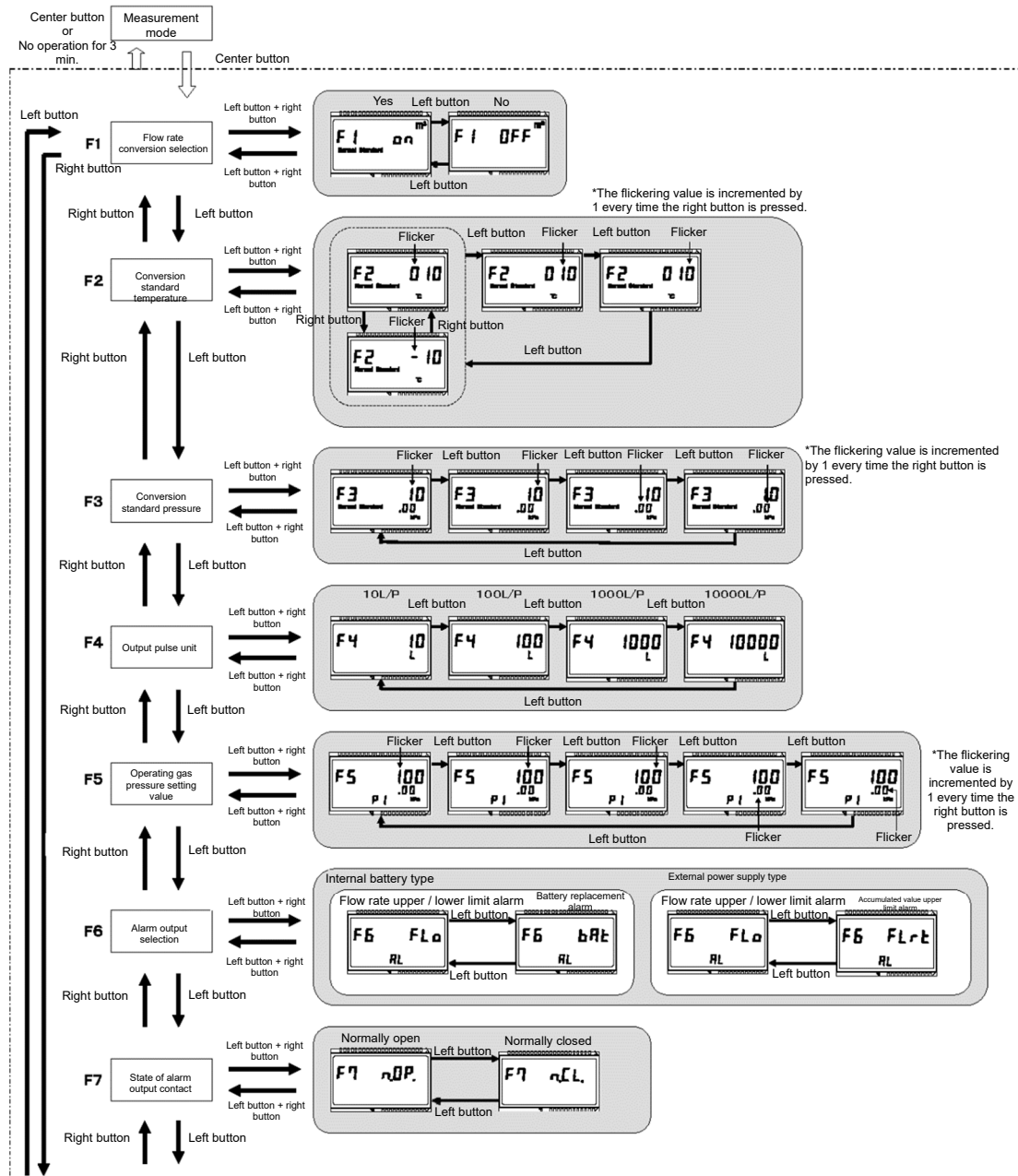

Fig. 7 Display changeover in each setting mode



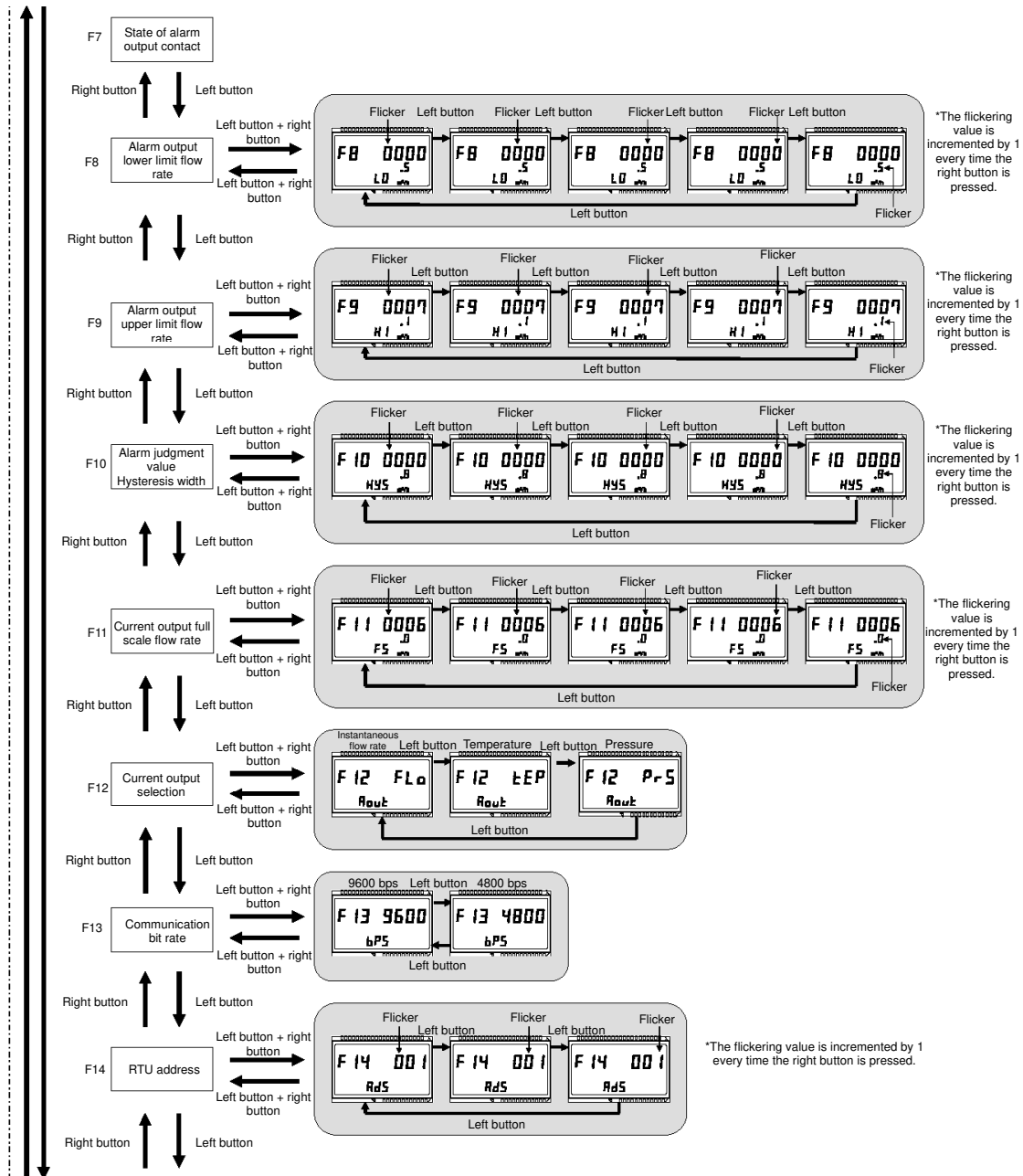

Fig. 8 Display changeover in each setting mode

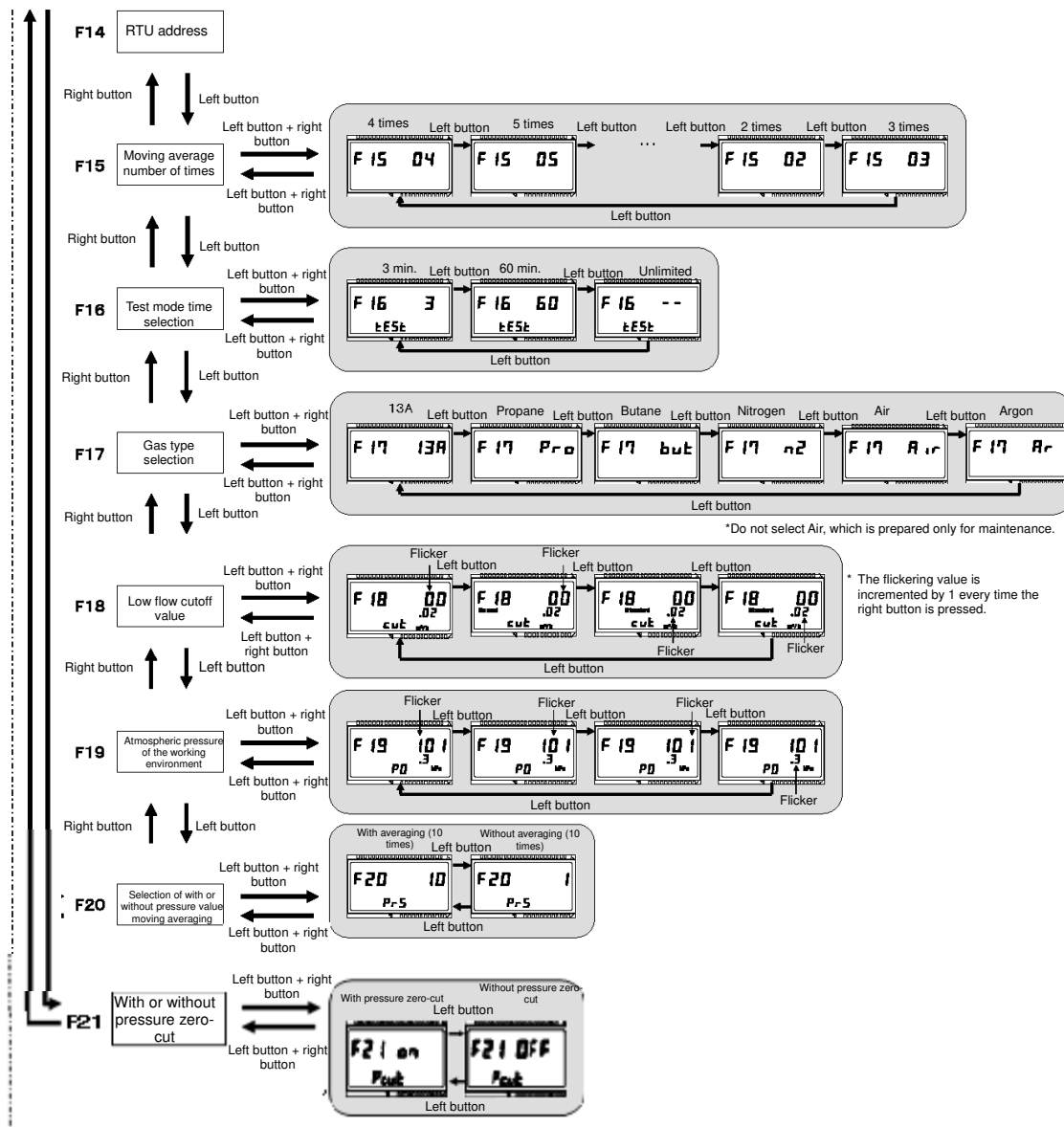

Fig. 9 Display changeover in each setting mode

## Warranty and after-sale service

### 1) Warranty period

For the period of one year after purchase, in case of a failure that is explicitly attributable to our manufacturing process, we will exchange the product for free.

### 2) Scope of warranty

The followings are not included in the scope of warranty.

Failure caused by force majeure, such as natural disaster, etc.

Disassembly or alteration of the product.

Failure caused by mishandling.

Failure caused by use in excess of the scope of the specifications (environment, etc.)

Other cases determined to be not attributable to our responsibility

Warranty specified here applies to our product itself, and any damage (loss and/or damage of any products other than our product, lost earning, and lost opportunity, etc.) incurred by the customer due to a failure of our product is excluded from the scope of warranty.

### 3) Requesting for service

Regardless of whether or not your warranty has expired, please contact the company you purchased the product from or our branch or sales office branch or sales office with the product name, model, construction work number, serial number, and a detailed description of the failure.

### 4) Points to note for long-term use



[Designed standard operating period] 10 years

The designed standard operating period refers to the standard period in which the product can be used after installation without safety problems against time-related degradation under the standard conditions (environment temperature 20°C, environment humidity 65%RH).

If you use the product longer than the designed standard operating period, safety problems of the product itself may occur such as deterioration of water-proof/dust-proof performance, smoke, fire, and electrical shock, etc.

If the designed standard operating period has passed, please use the product as checking if there is any failure in the product and consider replacing it with a new one.

The designed standard operating period is different from the warranty period. It does not guarantee that a general failure will not occur.

○ Contact

# Aichi tokei denki co.,ltd.

1-2-70 Chitose, Atsuta-ku, Nagoya, 456-8691, Japan

URL : <https://www.aichitokei.net/>

Ver. 11

2021.04