

Ultrasonic Flow Meter for Natural Gas and Factory Air AS-W, AS-C (Ver. 5) [EU and UK Specifications] Instruction Manual



Aichi Tokei Denki Co., Ltd.

Ultrasonic Flow Meter for Natural Gas and Factory Air AS-W, AS-C

[EU and UK Specifications] Instruction Manual

● Table of Contents

○ Important Notes & Requests

○ Product Overview

○ Product Model

○ Important Notice 3

○ For Safe and Proper Use 3

1. Introduction 6

1-1. Checking the Contents of the Package

1-2. Part Names

1-3. Steps to Start Operation

2. Activation 8

3. Configuration 9

3-1. Standard Factory Defaults

3-2. Configuration Change Procedure

3-3. Details of Configuration Items

4. Installation 18

5. Wiring 23

6. Operation 24

7. Operation Description of the Display Section 24

8. Error Display and Output 27

9. Specifications 29

10. External View 32

11. Battery Life 32

12. Troubleshooting 33

- Warranty and After-Sales Service Back-cover

○ Important Notes & Requests

Thank you very much for purchasing our ultrasonic flow meter for natural gas and factory air AS-W and AS-C. Before using this product, be sure to read this instruction manual to ensure safe and proper use.

This manual is also required for maintenance. Please keep the manual in a safe place until this product is disposed of.

○ Product Overview

This flow meter is an ultrasonic flow meter for natural gas or factory air, and can measure the flow rate of natural gas and air in the following range. Installation on piping is done with a flange.

- Atmospheric pressure to 0.5 MPa abs or less Target Nominal Diameter: 25A, 32A
 - Atmospheric pressure to less than 1 MPa abs Target Nominal Diameter: 40A to 200A
- *Use AS-W-150 and AS-W-200 under 0.15MPa abs.

○ Product Model

Product models are classified according to specifications, nominal diameter and pressure sensor specifications as follows.

AS [Specification] - [Nominal Diameter] - [Pressure Sensor Specification] BA/5

[Specification]

Natural Gas Specification: -W

Air Specification: -C

[Nominal Diameter]

25A: 25

32A: 32

40A: 40

50A: 50

80A: 80

100A: 100

150A: 150

200A: 200

[Pressure Sensor Specification]

No pressure sensor : 0 (For all nominal diameters)

With 0.2 MPa pressure sensor : 200 (For all nominal diameters)

With 0.5 MPa pressure sensor : 500 (For all nominal diameters)

With 1.0 MPa pressure sensor : 1000 (For 40A to 200A)

*1 25A and 32A are AS-W only.

*2 Use AS-W-150 and AS-W-200 under 0.15MPa abs.

*3 AS-C is 40A to 200A only.

B: Built-in battery model









A: Absolute pressure sensor

5: Version

○ Important Notice





To ensure safe use of this product and to avoid malfunctions or unexpected situations, this manual uses the following symbols to indicate precautions.

Symbols in the Manual

 Danger	This symbol indicates that death or serious injury will result if the information is ignored and the product is handled incorrectly.
 Warning	This symbol indicates that death or serious injury is likely if the information is ignored and the product is handled incorrectly.
 Caution	This symbol indicates that if the information is ignored and the product is handled incorrectly, personal injury or property damage (e.g., product failure) may result.
	 This symbol indicates that mishandling may result in an accident.
	 This symbol indicates an inhibited operation or action.
	 This symbol indicates what you must follow.

○ For Safe and Proper Use

Precautions for Use

 Danger	<ul style="list-style-type: none"> 1. Do not use the flow meter in applications requiring safety such as nuclear power, railways, aviation, vehicles, and recreational equipment. 2. Do not modify the flow meter. 3. The flow meter is not designed for sanitary use and should not be used for food, beverage, or medical applications.
--	--

Operating Environment and Measurable Fluids

Caution 

- ⊘ 1. Do not flow any gas other than natural gas or air through this flow meter.
- ⓘ 2. Observe the temperature and humidity ranges (-20 to +40°C, 90%RH or lower) and the pressure range.
- ⊘ 3. Do not use in an atmosphere containing corrosive gases (chlorine, hydrogen sulfide, etc.) or apply to fluids containing corrosive gases.
- ⊘ 4. This flow meter is not fully waterproof (IP65). Do not install the flow meter where it may be submerged in water.
- ⓘ 5. Install the flow meter as far away from an electric noise source as possible. If it is installed near the electric noise source, ground the shield of the external connection cable.
6. When the flow meter is installed in a location exposed to direct sunlight, it is recommended to install a sunshade.
7. Ultrasonic measurement may not be possible due to the relationship between methane concentration and working pressure value. Observe the following working pressure conditions for methane concentration.

Nominal Diameter	Methane Concentration Range	Working Pressure (absolute)
200A	Over 97 to 100%	Not available
	97% or less	No restrictions
150A	Over 98 to 100%	100 kPa or more
	98% or less	No restrictions

*No restriction for the 100A or lower models.

Operational Precautions

Warning 

- ⊘ 1. Do not use this flow meter as a scaffold or do not get on it.
- ⊘ 2. Do not hold the display section of this flow meter.
This flow meter is a precision measuring instrument, so please hold the part shown below.

○ Correct

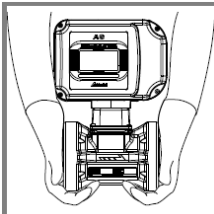

○ Correct

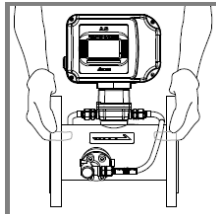

✗ Incorrect

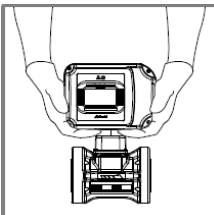

✗ Incorrect

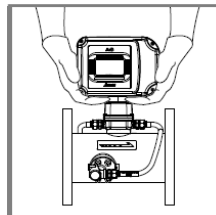

✗ Incorrect

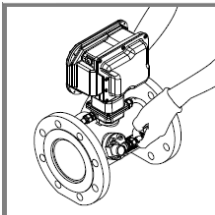

- ⊘ 3. Do not press down on the glass part.

Caution 

- ⓘ 1. When opening and closing the valve, do not operate the valve at once. Open and close it slowly. Rapid opening and closing of the valve when there is a pressure difference between the upstream and downstream sides of the valve can cause the flow meter to fail.



Storage

 Caution	<ul style="list-style-type: none">⊘ 1. Keep away from fire and direct sunlight.⊘ 2. Do not place combustible materials, flammable substances, or heating elements around the flow meter.ⓘ 3. Store the flow meter in a place where the ambient temperature is -25 to +70°C and there is no condensation.
---	--

Piping

 Caution	<ul style="list-style-type: none">1. Install flow regulating valves or other flow-disturbing devices downstream of the flow meter.2. If the piping is new, clean the piping thoroughly before installation.3. Vertical piping is recommended if there is a lot of mist or dust. In the case of horizontal piping, install the flow meter so that the display section is facing upward.4. Do not install the flow meter where it will be subjected to strong compressive or tensile forces or other loads after installation.5. Install pipes in accordance with the flow direction indicated on the flow meter.6. Do not drop, strike, or subject the flow meter to excessive shock.7. When rotating the display section, do not apply any force other than the direction of rotation.ⓘ 8. Do not touch the ultrasonic sensors.
---	--

Wiring

 Danger	<ul style="list-style-type: none">ⓘ 1. When wiring, follow the instructions in this manual.ⓘ 2. Observe the rated range. ⊘ Do not use the flow meter at voltages exceeding the allowable load.
 Caution	<ul style="list-style-type: none">1. Do not wire the product together with power or motor cables.2. Do not apply excessive tensile force to the external connection cable.3. Make sure that the tip of the external connection cable is not submerged in water during wiring work.ⓘ 4. Be careful not to short-circuit when connecting the power line of the external connection cable to an external power supply. Use an external power supply with short-circuit protection.ⓘ 5. Be sure to stop the external power supply before wiring.⊘ 6. Do not perform operation and the wiring work with wet hands.

Disassembly and Inspection

 Caution	<ul style="list-style-type: none">⊘ 1. Do not disassemble the flow meter.2. When fluid flow is normal, the pilot lamp will blink. If it does not blink, please contact us.3. When a lot of mist and dust is contained in the fluid, periodically remove the flow meter to check for dust or other debris and remove it as necessary.ⓘ Remove the flow meter from the piping, cover one side, and clean it with water or spindle oil. (See "ALARM1 turns on" in "After Operation" in "12. Troubleshooting" for details.)ⓘ Do not touch the ultrasonic sensors during inspection.
---	---

Disposal

 Warning	<ul style="list-style-type: none">ⓘ 1. This flow meter contains a built-in lithium thionyl chloride battery. Never dispose of this flow meter in the general disposal route.ⓘ 2. Be sure not to put the flow meter into fire. It may cause fire and/or explosion.
---	--

1. Introduction

1-1. Checking the Contents of the Package

When you receive our company product, please check that the following items are included in the package.

Name	Qty.	Remarks
Ultrasonic flow meter	1	
Centering collar	2	See page 21 for details on how to use.
M4 hexagonal wrench	1	Used to tighten the set screw to change the orientation of the display section and push the rear center button (SW3).
Instruction Manual (this book)	1	



M4 hexagonal wrench



Instruction Manual
(this book)



Centering collar

1-2. Part Names

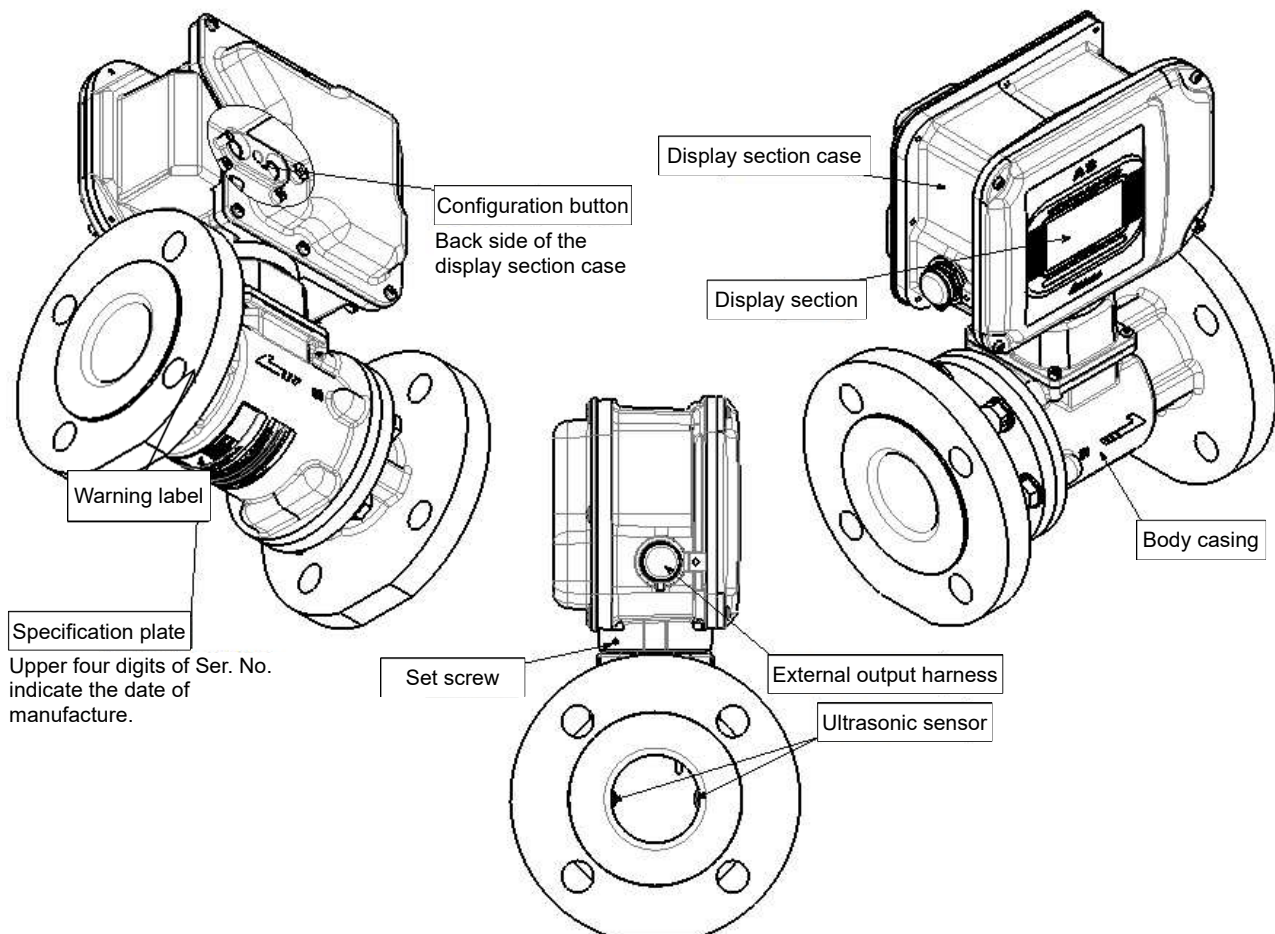

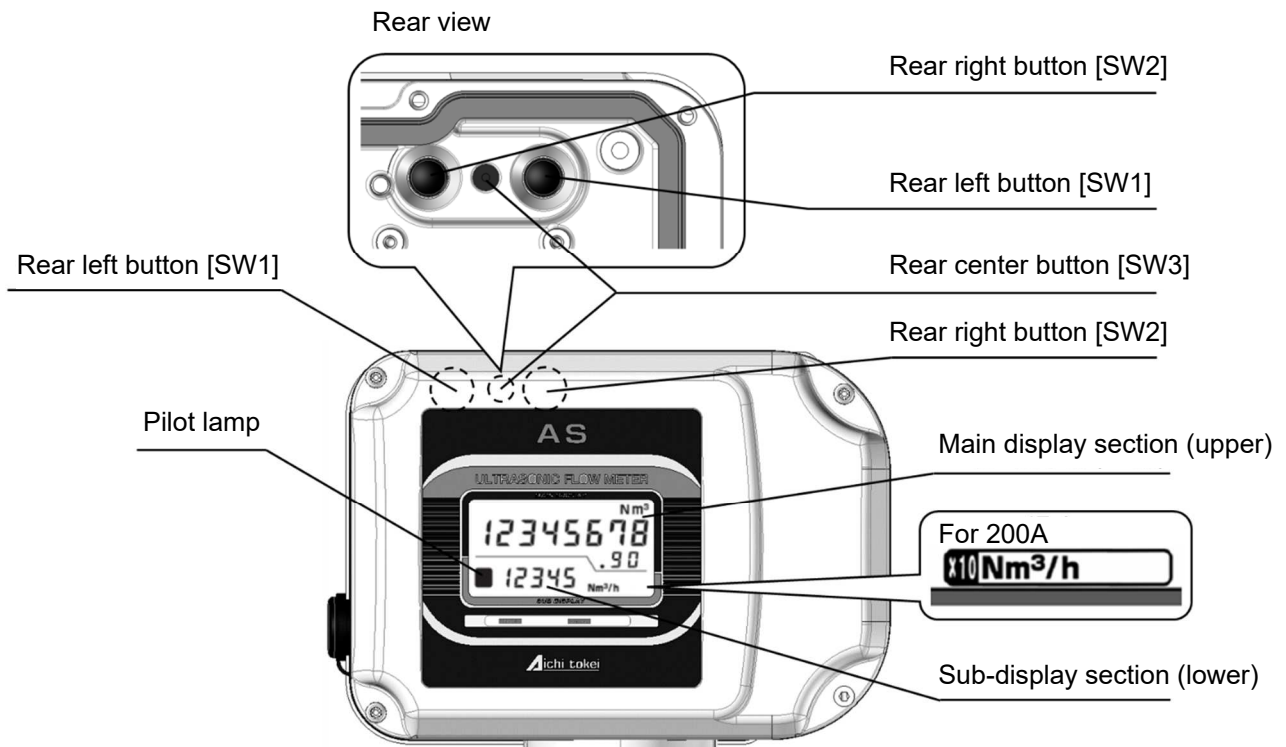
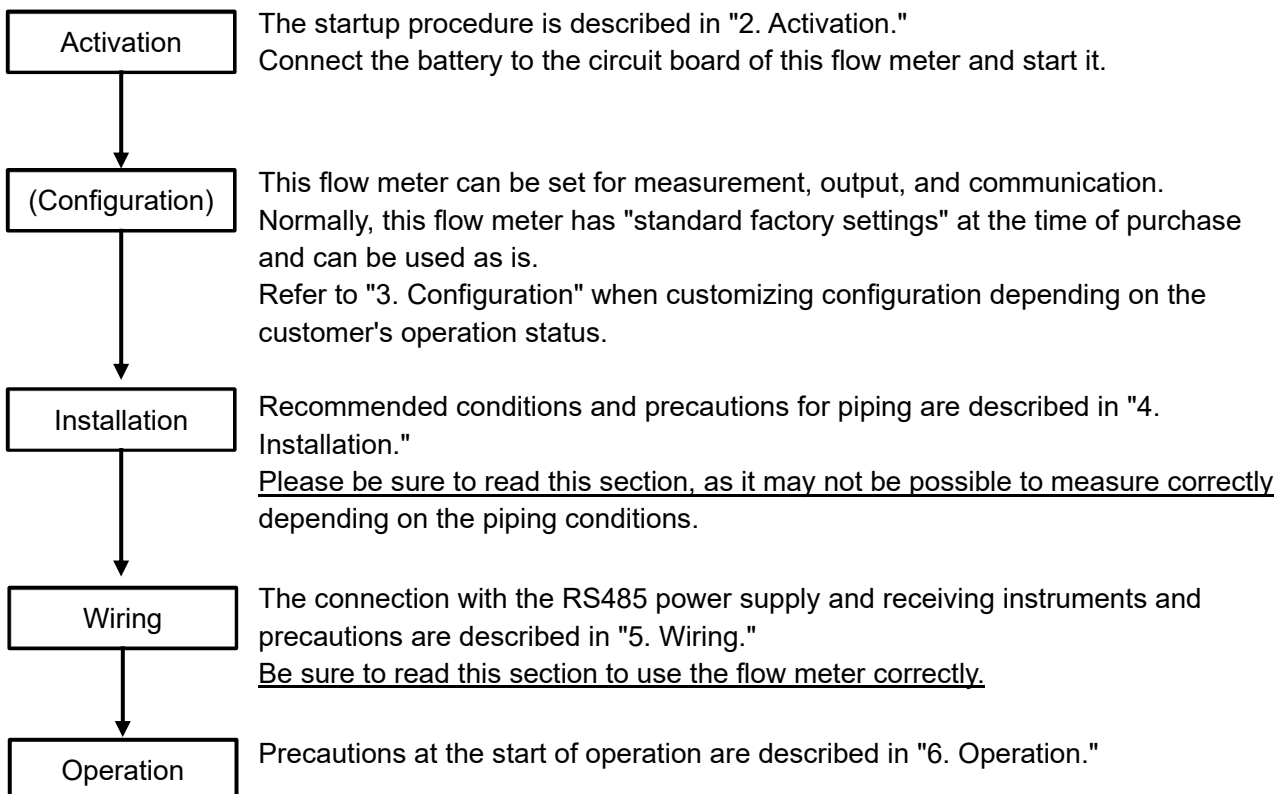

Fig. 1-1. Part Names of Operation and Display Sections

1-3. Steps to Start Operation

The basic steps to start operation are as follows.

Flow meter configuration can be done after installation, but should be done before installation as output may be unstable for a few seconds immediately after configuration changes.



2. Activation

- (1) Use a Phillips screwdriver to remove the screws and open the lid.
- (2) Place the supplied battery in the case on the right side of the board. At this time, insert the battery with the side with the cable coming out down as shown below. (The battery may already be installed.)
- (3) Peel off the temporary fixing tape that secures the cable.
- (4) Connect the connector to the board so that the black cable is up and the red cable is down. Be sure to insert the connector all the way to the back.

*Immediately after startup, the LCD blinks. Please wait until the display switches to the lit display.

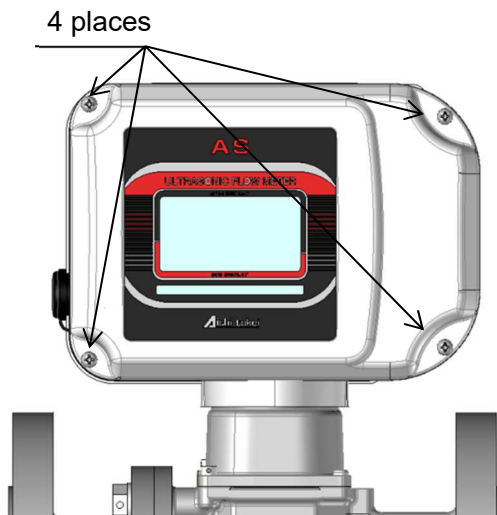

(1) Remove the screws.

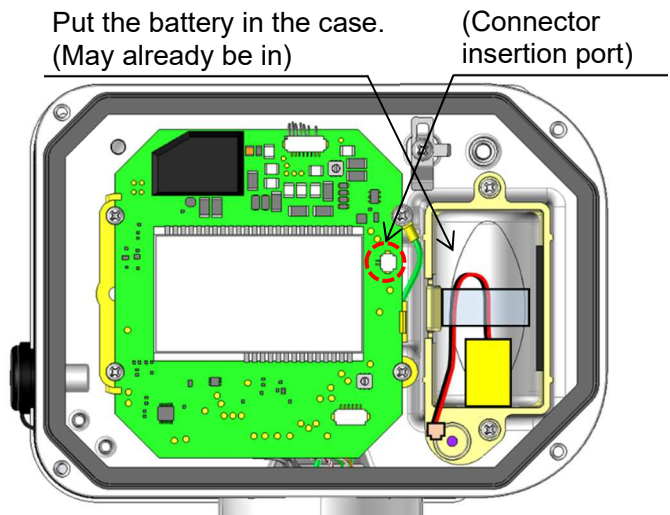

(2) Put the battery in the case.

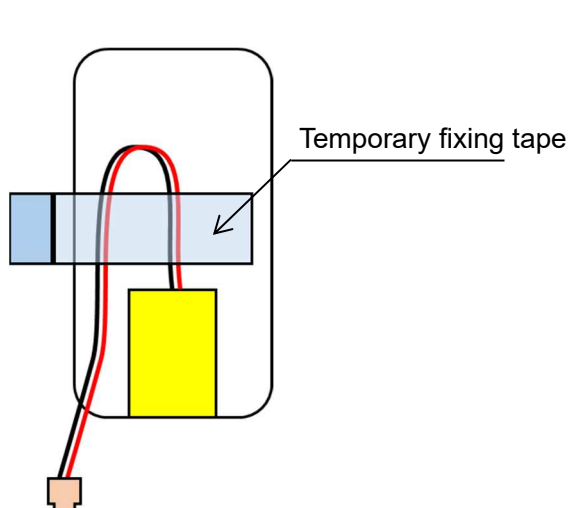

(3) Peel off the temporary fixing tape.

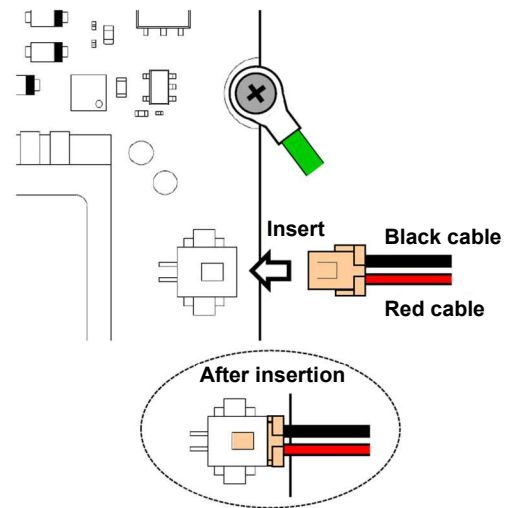

(4) Connect the connector to the board.

⚠*1 Static electricity applied to the board may cause product failure. We recommend that you wear anti-static gloves when working.

*2 After installing the battery, securely attach the gasket and close the lid. The screws should be tightened diagonally with even torque. (Recommended torque: 1.0 [N·m])

3. Configuration

3-1. Standard Factory Defaults

This flow meter allows various settings related to measurement, output, and communication. (Table 3-1)

This flow meter has factory settings at the time of purchase and can be used as is.

To change the factory settings, follow the procedure in "3-2. Configuration Change Procedure."

Table 3-1. Configuration Items and Standard Factory Settings

Category 1		Category 2		Category 3	Scope of configuration	Factory default settings
Item No.	Item	Item No.	Item	Item		
F0	Software version	-	-	-	-	-
F1	Measurement	F1-1	Flow measurement related	Maintenance	-	-
				Maintenance	-	-
				Selection of displayed accumulated flow rate	Act: Forward actual accumulated value Std: Forward converted accumulated value	Std
				Instantaneous flow moving average times	1 to 16 [times]	4
				Conversion reference temperature	-10.0 to +60.0 [°C]	0.0
				Conversion reference pressure	0.00 to 10.00 [kPa]	0.00
		F1-2	Pressure measurement related	Enable/Disable supply gas pressure setting	OFF: Disabled ON: Enabled	[Pressure Sensor Specification] 0: ON 200, 500, 1000: OFF
				Supply gas pressure	0.0 to 1000.0 [kPa]	[Pressure Sensor Specification] 0: 101.3 200, 500, 1000: 0.0
				Pressure value moving average times	1 to 4 [times]	1
		F1-3	Compressibility factor calculation related	Compressibility factor fixed value	0.800 to 1.200 0.000: Fixed value setting disabled	1.000
				Methane CH ₄	0.000 to 1.000	0.800
				Nitrogen N ₂	0.000 to 1.000	0.000
				Carbon dioxide CO ₂	0.000 to 1.000	0.000
				Ethane C ₂ H ₆	0.000 to 1.000	0.200
				Propane C ₃ H ₈	0.000 to 1.000	0.000
				Isobutane i-C ₄ H ₁₀	0.000 to 1.000	0.000
				Butane C ₄ H ₁₀	0.000 to 1.000	0.000
				Isopentane i-C ₅ H ₁₂	0.000 to 1.000	0.000
				Pentane C ₅ H ₁₂	0.000 to 1.000	0.000
				Hexane C ₆ H ₁₄	0.000 to 1.000	0.000
				Heptane C ₇ H ₁₆	0.000 to 1.000	0.000
				Octane C ₈ H ₁₈	0.000 to 1.000	0.000
				Nonane C ₉ H ₂₀	0.000 to 1.000	0.000
Decane C ₁₀ H ₂₂	0.000 to 1.000	0.000				
Hydrogen H ₂	0.000 to 1.000	0.000				
Oxygen O ₂	0.000 to 1.000	0.000				

Category 1		Category 2		Category 3	Scope of configuration	Factory default settings
Item No.	Item	Item No.	Item	Item		
F1	Measurement	F1-3	Compressibility factor calculation related	Carbon monoxide CO	0.000 to 1.000	0.000
				Water H2O	0.000 to 1.000	0.000
				Hydrogen sulfide H2S	0.000 to 1.000	0.000
				Helium He	0.000 to 1.000	0.000
				Argon Ar	0.000 to 1.000	0.000
F2	Maintenance	-	Maintenance	Maintenance	-	-
F3	Output	F3-1	Flow rate pulse output related	Selection of pulse output flow rate	Act: Actual flow rate Std: Converted flow rate	Std
				Unit pulse output unit	100, 1000, 10000 [L]	1000
				Maintenance	-	-
		F3-2	Communication related	Pulse output ON width	50, 125, 250, 500, 1000 [ms] Duty	duty
				Communication bit rate	4800, 9600 [bps]	4800
			RTU address	000 to 255	001	
F4	Maintenance	-	Maintenance	Maintenance	-	-
F5	Maintenance	-	Maintenance	Maintenance	-	-
-	Blank	-	-	-	-	-

3-2. Configuration Change Procedure

To change the configuration, refer to the display switching flow (Fig. 3-1) and operate the buttons. The buttons can be operated by removing the lid on the back side. To press SW3, use the supplied hexagonal wrench or similar tool.

⚠*1 Do not press SW3 with a sharp object as it may cause damage.

***2** After changing the configuration, securely attach the gasket and close the lid. The screws should be tightened diagonally with even torque. (Recommended torque: 1.0 [N·m])

Screws to prevent falling off
(8 places)

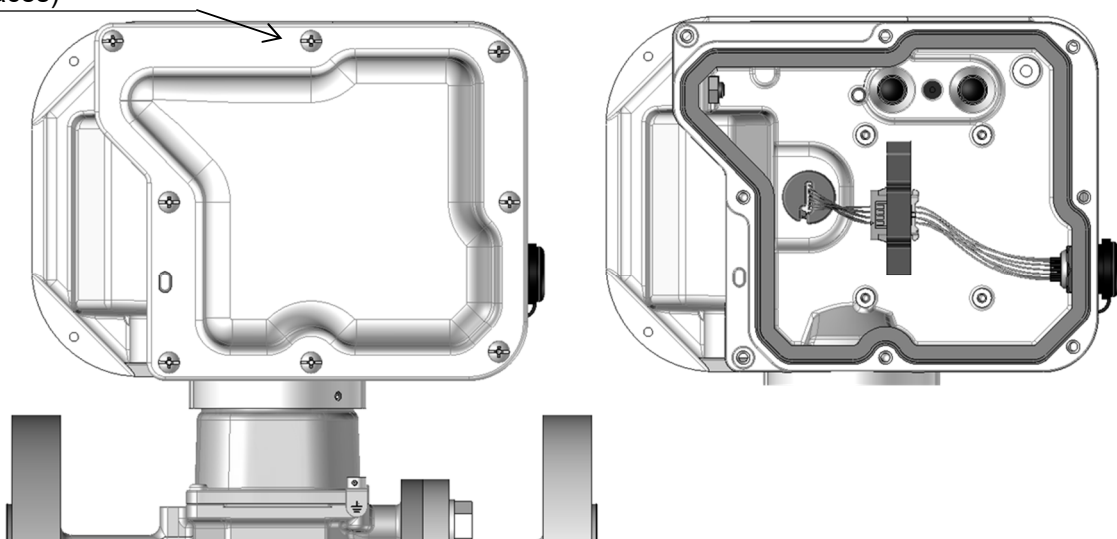

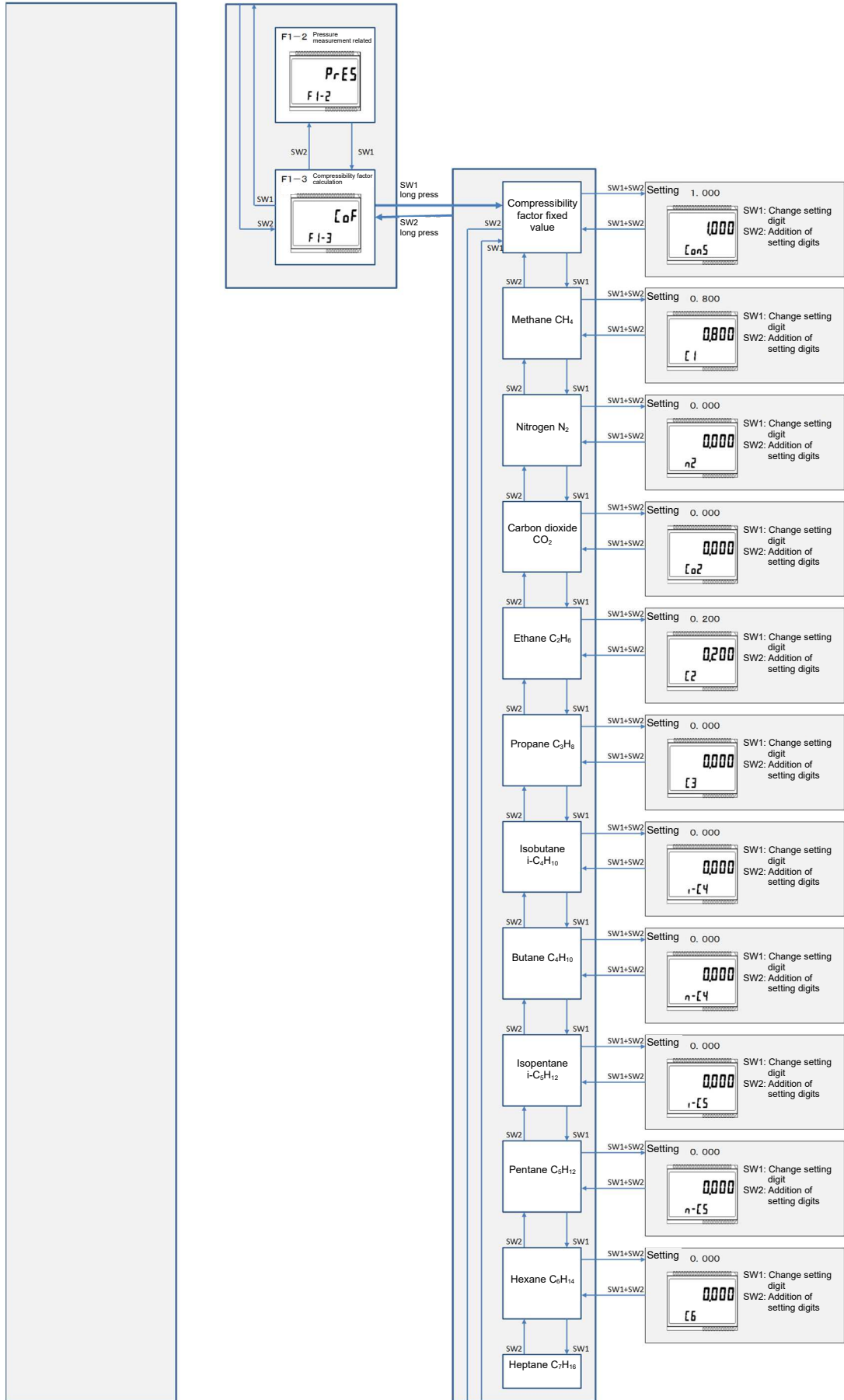

Fig. 3-1. Display Switching Flow (2/4)

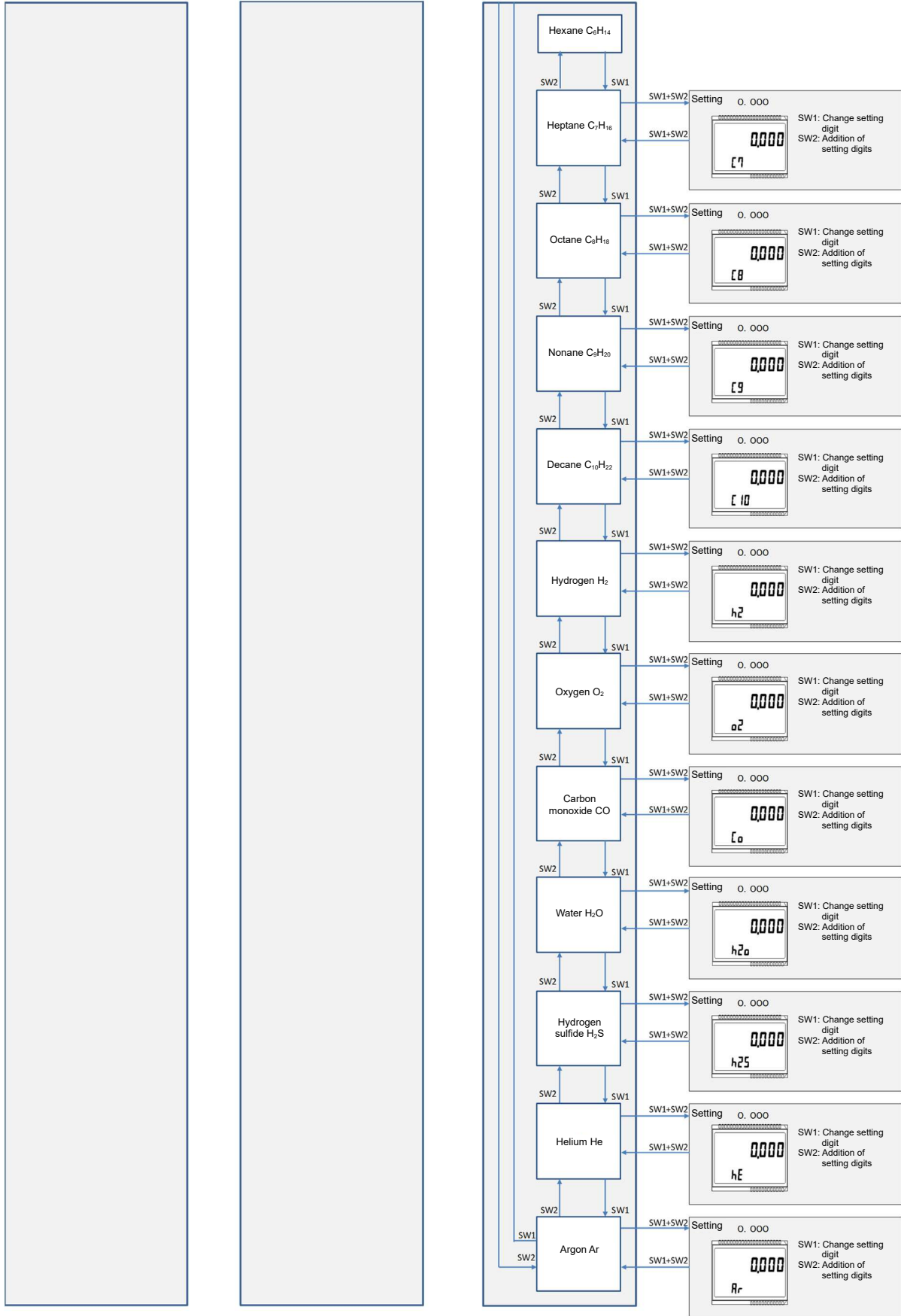

Fig. 3-1. Display Switching Flow (3/4)

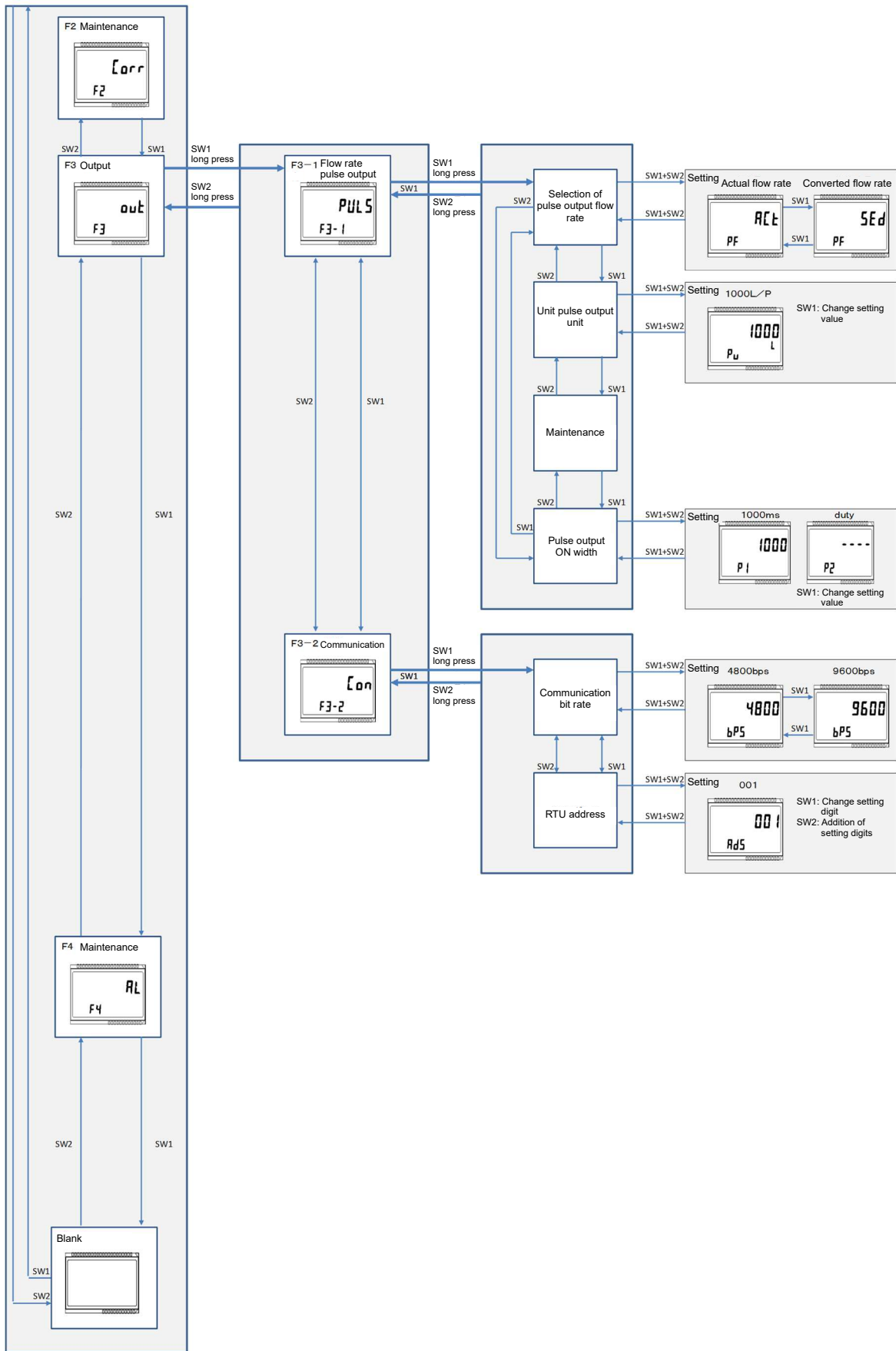

Fig. 3-1. Display Switching Flow (4/4)

3-3. Details of Configuration Items

- [F1-1] Selection of Displayed Conversion

Select the accumulated forward flow rate on the main display from "Actual flow rate (Act)" or "Converted flow rate (Std)." The factory default for this flow meter is "Converted flow rate (Std)."

- [F1-1] Instantaneous flow moving average times

Select the moving average times for displaying and outputting the instantaneous flow. The factory default setting for this flow meter is 4 times, and the last 4 times measurement values are used.

Although there is no need to change the moving average times in normal use, you can select "No moving average (01)," "2 times (02)," "3 times (03)," ... "14 times (14)," "15 times (15)," or "16 times (16)."

- [F1-1] Conversion reference temperature

For flow rate conversion, set the reference temperature within the range of -10.0 to +60.0°C. The factory default is "0.0°C."

- [F1-1] Conversion reference pressure

For flow rate conversion, set the reference pressure in increments of 0.01 kPa within the range of 0.00 to 10.00 kPa (gauge pressure). The factory default is "0.00" kPa.

- [F1-2] Enable/Disable supply gas pressure setting

Select "Enable (ON)" or "Disable (OFF)" for enable/disable of the setting value of working pressure.

The factory default for this flow meter is "Enable" when the pressure sensor specification is 0, and "Disable" when it is other than 0.

- [F1-2] Supply gas pressure

Set the working pressure within the range of "0.0 kPa (0.0)" to "1000.0 kPa (1000.0)."

The factory default setting is "101.3 kPa (101.3)" when the pressure sensor specification is 0, and "0.0 kPa (0.0)" when it is other than 0. Used when the supply gas pressure setting is set to "Enable (on)."

- [F1-2] Pressure value moving average times

Select the moving average times for pressure display from "Once (1)" to "4 times (4)." Setting "Once (1)" disables moving average.

- [F1-3] Compressibility factor fixed value

Select the compressibility factor correction value from "0.800" to "1.200" and "0.000." When "0.800" to "1.200" is set, the fixed setting value becomes valid and is used for flow conversion. When "0.000" is set, the fixed setting value becomes invalid and the compressibility factor calculated by composition input is used for flow conversion. The factory default for this flow meter is "1.000."

● [F1-3] Gas composition

When the compressibility factor fixed value is set to "0.000," which is invalid, this gas composition is used to determine the compressibility factor inside the flow meter. Twenty-one (21) types of gas composition can be entered. (CH₄, N₂, CO₂, C₂H₆, C₃H₈, H₂O, H₂S, H₂, CO, O₂, i-C₄H₁₀, n-C₄H₁₀, i-C₅H₁₂, n-C₅H₁₂, n-C₆H₁₄, n-C₇H₁₆, n-C₈H₁₈, n-C₉H₂₀, n-C₁₀H₂₂, He, Ar)

The calculation method is based on ISO 12213-1:2006 and ISO 12213-2:2006. The gas composition is set in mole fractions from "0.000" to "1.000." Enter the total gas composition to be 1.000.

When gas composition is entered or when the battery is turned on, the mode is automatically shifted to "Compressibility factor calculation mode." "Compressibility factor calculation mode" stops ultrasonic measurement and output. After the calculation of the compressibility factor is completed, it automatically enters the measurement mode. If a fixed value is entered, the mode does not shift to the "Compressibility factor calculation mode."

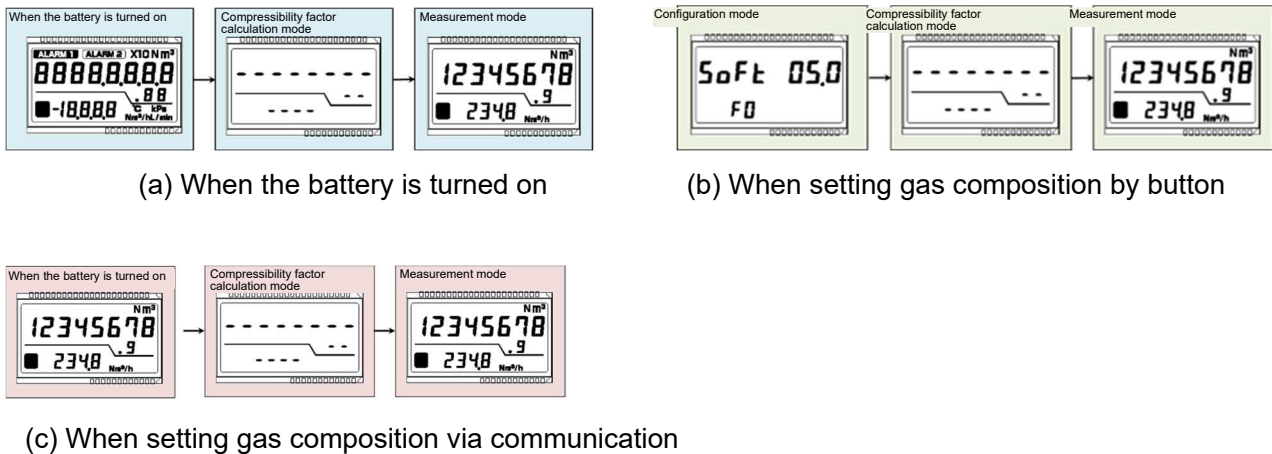

Fig. 2-2. Compressibility Factor Calculation Mode Display

● [F3-1] Selection of pulse output flow value

Select the pulse output flow value. "Converted flow rate (std)" is selected as the default setting for this flow meter. In the "Actual flow rate (Act)" mode, the output signal corresponds to the actual flow.

In the "Converted flow rate (Std)" mode, the output signal corresponds to the conversion flow.

The converted flow rate is calculated based on the temperature t [°C] and pressure p [kPa] measured at the same time as the flow rate.

$$Q_2 = Z \times (T_2 / (T_1 + t)) \times (p / P_1) \times Q_1$$

Q_2 : Converted flow rate [Nm³/h]

Z : Compressibility factor

Q_1 : Actual flow rate [m³/h]

T_2 : Absolute temperature of conversion reference temperature [K]

T_1 : Absolute temperature of 0°C (= 273.15 [K]) t : Fluid temperature [°C]

P_1 : Absolute pressure of conversion reference pressure [kPa abs]

p : Measurement pressure (absolute pressure) [kPa abs]

● [F3-1] Unit pulse output unit

Select the output unit from "10000," "1000," or "100" (unit: [L/P] or [NL/P]). This is reflected in the output unit pulse of the contact output (unit pulse: forward flow). The range of setting values that can be selected is limited according to the nominal diameter.

Table 2-2 shows the selectable ranges for each nominal diameter.

When the unit pulse output unit is changed, the pulse output ON width is automatically set to "Duty 50%."

Table 2-2. Selectable Range

[One-shot]

<40A>

Pulse ON width [ms]	Pulse output unit [L/P] / [NL/P]		
	100	1000	10000
50	○	○	○
125	○	○	○
250	×	○	○
500	×	○	○
1000	×	○	○

<50A>

Pulse ON width [ms]	Pulse output unit [L/P] / [NL/P]		
	100	1000	10000
50	○	○	○
125	×	○	○
250	×	○	○
500	×	○	○
1000	×	○	○

<80A>

Pulse ON width [ms]	Pulse output unit [L/P] / [NL/P]		
	100	1000	10000
50	○	○	○
125	×	○	○
250	×	○	○
500	×	○	○
1000	×	×	○

<100A>

Pulse ON width [ms]	Pulse output unit [L/P] / [NL/P]		
	100	1000	10000
50	×	○	○
125	×	○	○
250	×	○	○
500	×	×	○
1000	×	×	○

<150A>

Pulse ON width [ms]	Pulse output unit [L/P] / [NL/P]		
	100	1000	10000
50	×	○	○
125	×	○	○
250	×	×	○
500	×	×	○
1000	×	×	○

<200A>

Pulse ON width [ms]	Pulse output unit [L/P] / [NL/P]		
	100	1000	10000
50	×	○	○
125	×	×	○
250	×	×	○
500	×	×	○
1000	×	×	×

[Duty 50%]

Nominal Diameter	Pulse output unit [L/P] / [NL/P]		
	100	1000	10000
40	○	○	○
50	○	○	○
80	○	○	○
100	×	○	○
150	×	○	○
250	×	○	○

○: Selectable
×: Not selectable

● [F3-1] Pulse output ON width

Select from duty method ["Duty 50% (----)"] or one-shot method [pulse ON width "50 ms (50)," "125 ms (125)," "250 ms (250)," "500 ms (500)," and "1000 ms (1000)"]. The factory default is "Duty 50% (----)."

The selectable pulse output units are limited according to the output method and one-shot pulse ON width. See Table 2-2 for details.

When the unit pulse output unit is changed, "Duty 50% (----)" is automatically set.

● [F3-2] Communication bit rate

Select the communication bit rate from "4800" or "9600" (bps). The factory default for this flow meter is "4800."

● [F3-2] RTU address

Select an RTU address from "000" to "255." The factory default for this flow meter is "001."

● Maintenance setting

Do not alter the settings for maintenance functions.

4. Installation

It is recommended that the setting operations (see "3. Configuration") and the orientation adjustment of the display section (see "4. Installation section 8)") be performed before the flow meter is installed.

○Applied piping

This flow meter satisfies the flow rate measurement accuracy with the recommended piping inner diameters in Table 4-1 below.

(If you use piping that differs from the recommended piping inner diameters in Table 4-1, the flow meter may not satisfy the flow rate measurement accuracy. If you are considering using a piping different from the recommended piping inner diameters in Table 4-1, contact us in advance.)

Table 4-2 shows an example of piping standards and dimensions where the piping inner diameter satisfies the requirements of Table 4-1.

Table 4-1. Recommended Piping Inner Diameter

Nominal Diameter	25	32	40	50	80	100	150	200
Piping Inner Diameter	25	32	40.3	50	79.9	100	150	199.1
Connection Method	ISO 7005-1 (GB/T9119-2000 PN1.6 MPa flange) equivalent							

Table 4-2. Example of Piping Standards and Dimensions Satisfying the Recommended Piping Inner Diameter

Piping Standard	ISO 7005-1							
Nominal Diameter (mm)	25	32	40	50	80	100	150	200
Outer Diameter (mm)	32	38	45	57	89	108	159	219
Thickness (mm)	3.5	3	2.5	3.5	4.5	4	4.5	9.5

○Piping conditions

- 1) Align the forward flow direction of the fluid with the arrow marked on the body.
- 2) For this flow meter, a straight pipe length as shown in Fig. 4-1 is recommended according to the piping conditions.

Conditions	Upstream	Downstream
90° elbow/full bore valve fully opened		
Joining		
Expanding pipe		
Narrowing pipe		

Fig. 4-1. Recommended Straight Pipe Length 1 (D: Nominal Diameter)

3) When the flow meter is installed near a pressure reducing valve or flow regulating valve, ultrasonic noise may be generated inside the piping. Therefore, strictly adhere to the "necessary straight pipe length L*" as shown in Fig. 4-2 below.

In particular, **please note that there are significant restrictions when installing the flow meter downstream of a pressure reducing valve. (If the necessary conditions are not met, measurement may not be possible.)**

*When using elbows, replace "necessary straight pipe length" with "necessary pipe length (including bent pipe)." Also, 10D before the flow meter should be provided as a straight pipe.

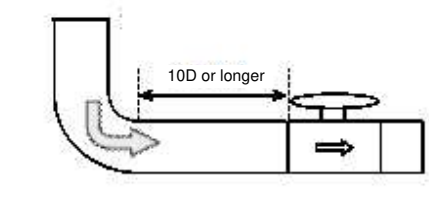
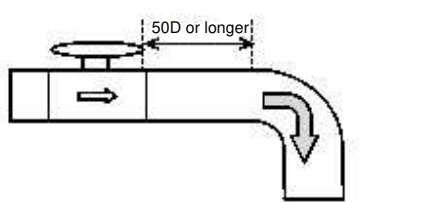
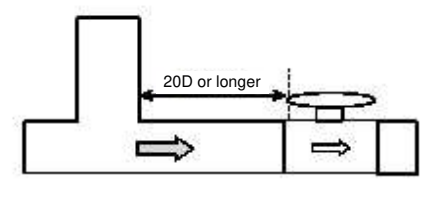
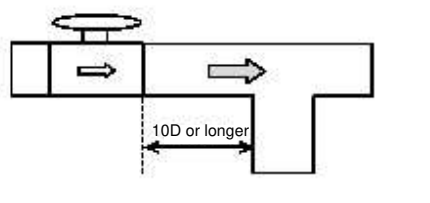
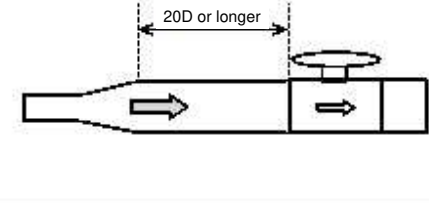
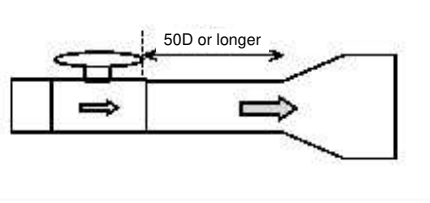
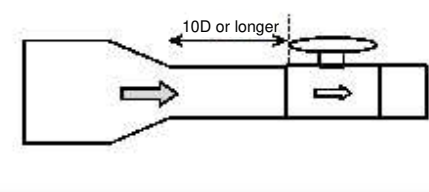
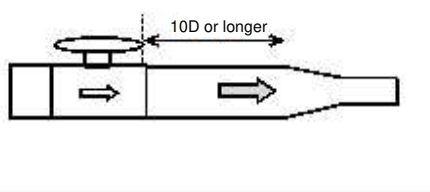
$\text{Necessary Straight Pipe Length } L \text{ (mm)} = 10D + \frac{\text{Differential Pressure [kPa]} \times D \times \frac{\text{Maximum Flow Velocity Used [m/s]}}{20 \text{ [m/s]}} \times (0.8)^{\text{Number of Elbows}}$
--

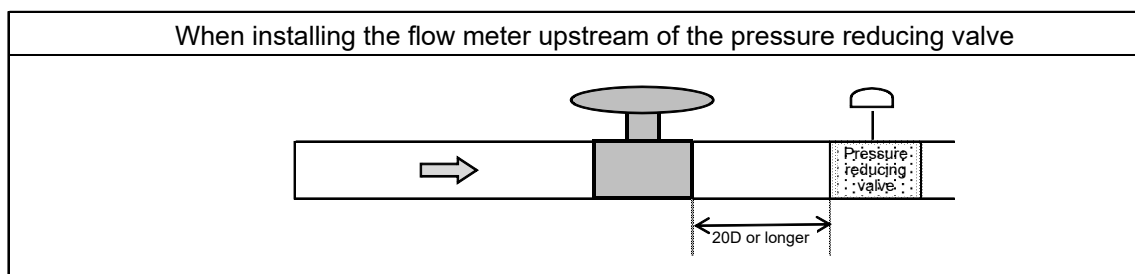
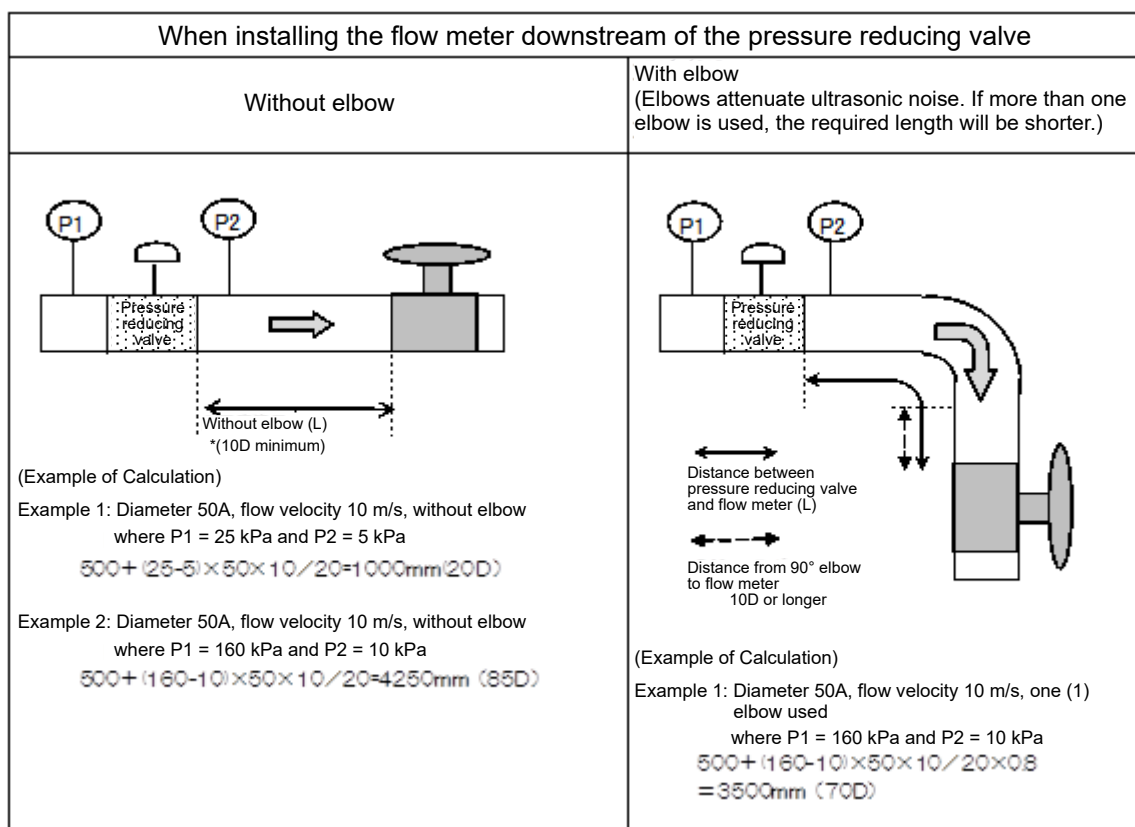

Fig. 4-2. Recommended Straight Pipe Length 2 (D: Nominal Diameter)
(When the Flow Meter is Installed Near a Pressure Reducing Valve or Flow Regulating Valve)

4) Install the flow meter so that the center axis of the flow meter and the center axis of the piping are aligned. Be sure to use the supplied centering collars to reduce the misalignment of the center axis between the flow meter and the piping. If the collars are not used, the flow meter cannot be used within the guaranteed accuracy range.

For upstream installation, as shown in Fig. 4-3, insert the supplied centering collars diagonally into the holes in the gasket and flange.

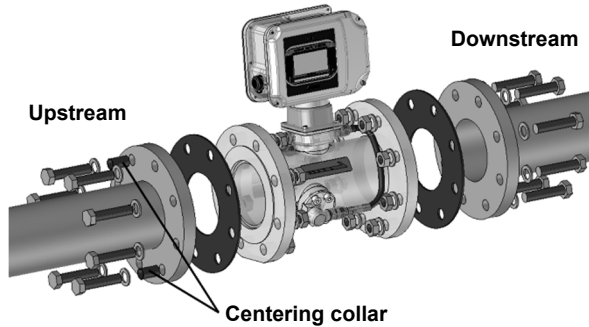

Fig. 4-3. Example of Installation of Centering Collars

5) This flow meter can be installed indoors or outdoors, and can be installed horizontally or vertically. Install it in the middle of the straight pipe section.

*1 When there is a lot of mist or dust in the piping, vertical piping is recommended.

*2 This flow meter is not fully waterproof (IP65). Do not install the flow meter where it may be submerged in water.

*3 When the flow meter is installed in a location exposed to direct sunlight, it is recommended to install a sunshade.

*4 If the flow meter is to be installed in a location where it will be exposed to rainwater, install it so that the display section does not face downward.

6) Flange type flow meters should be secured with M12 (for nominal diameter 25A), M16 (for nominal diameters 32A, 40A, 50A, 80A, and 100A) or M20 (for nominal diameters 150A and 200A) bolts and nuts with torque within the range shown below (see Fig. 4-3.). When tightening, use even force to avoid one-sided tightening.

AS25: 80 to 100 N·m	AS32: 140 to 160 N·m
AS40: 160 to 180 N·m	AS50: 220 to 240 N·m
AS80: 330 to 350 N·m	AS100: 130 to 150 N·m
AS150: 290 to 310 N·m	AS200: 240 to 260 N·m

7) Care should be taken to ensure that the gasket to be installed on the flange does not protrude into the piping.

- 8) You can change the orientation of the display section by rotating it. It is recommended to rotate the display section before installing the flow meter. To change the orientation of the display section, loosen the set screws in the neck of the display section with the supplied M4 hex wrench, and then rotate the display section. Once the display section is rotated in the desired orientation, be sure to tighten the set screws to secure the display section.

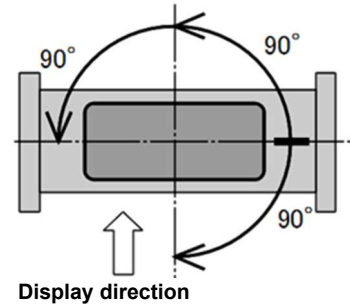

*1 The display section can be turned 90° clockwise and 180° counterclockwise from the factory set position.

*2 When rotating the display section, do not apply any force other than the direction of rotation.

- 9) Be careful not to let foreign objects such as welding tips, dust or sealants enter the piping. If the piping is new, clean the piping thoroughly before installation.
- 10) Do not install the flow meter where it will be subjected to strong compressive or tensile forces or other loads after installation.
- 11) When piping, do not touch the inside of the flow meter, especially the ultrasonic sensors. (See "1-2. Part Names".)
- Also, do not drop, strike, or subject the flow meter to excessive shock.
- ⊘ Do not hold the display section of this flow meter.

5. Wiring

Use the optional external connection cable to connect as follows.

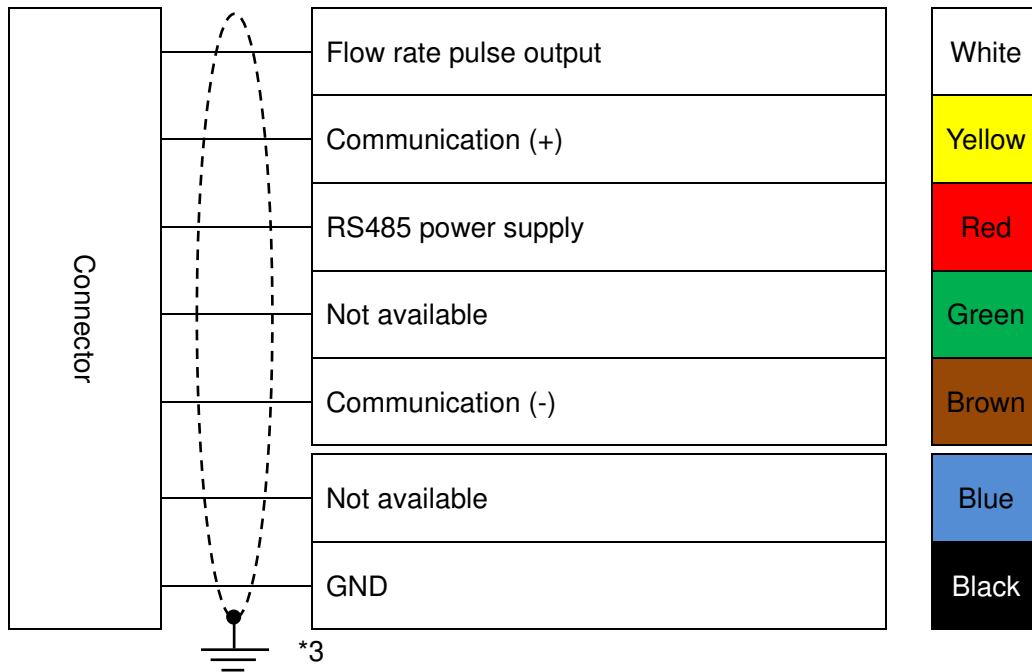

Fig. 5-1. External Connection Cable Wiring Diagram

*1 The body and GND are electrically common.

*2 If necessary, use an isolated power supply and indicator.

*3 If the flow meter is installed near a noise source, ground the braided shield attached to the external connection cable.

Note: For cable length

When extending the external connection cable, use the cable lengths shown below as a guide.

- Communication line (cable color: brown, yellow) : Up to 100 m
- Signal line (cable color: white, green, blue, red, black) : Up to 20 m

*1 For cable extension, "UL20276" 7 × 0.14 mm² cable is recommended.

*2 The maximum cable length may vary depending on the installation environment, connection equipment, and type of cable used.

*3 If the cable is too long, the signal may be attenuated or noise may be easily superimposed.

6. Operation

⚠ Do not open and close the valve at once, but open and close slowly.

Rapid opening and closing of the valve when there is a pressure difference between the upstream and downstream sides of the valve can cause the flow meter to fail. When starting operation, make sure the pilot lamp is blinking. (A blinking pilot lamp indicates fluid flow.)

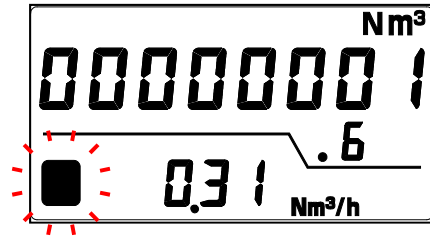

Note: At the start of operation

When installing and starting operation of the flow meter, the ALARM1 may turn on in rare cases due to a sudden change in pressure from atmospheric air pressure. However, the ALARM1 will turn off once the fluid stabilizes under the operating pressure. (This is not an error.)

7. Operation Description of the Display Section

A. Operation

- 1) In normal (measurement mode), the main display section (upper part) shows the forward converted accumulated value or forward actual accumulated value, and the sub-display section (lower part) shows the instantaneous converted flow rate, instantaneous actual flow rate, pressure or working pressure, temperature, and maintenance by automatic switching every 2.5 seconds. (Fig. 7-1)
- 2) The three buttons on the back of the display section allow you to make various local settings.
- 3) See Fig. 1-1 for the location of "SW1," "SW2" and "SW3."
- 4) By operating the buttons shown in Table 7-1, you can shift to various modes as shown in Fig. 7-1.

Table 7-1. Switching Method between Measurement and Configuration Modes

Button operation	Measurement mode	Configuration mode	
		Configuration display	Configuration change
SW3	Switch to configuration mode	Switch to measurement mode	
SW1 + SW2 (simultaneous press)		Switching between configuration display and configuration change	

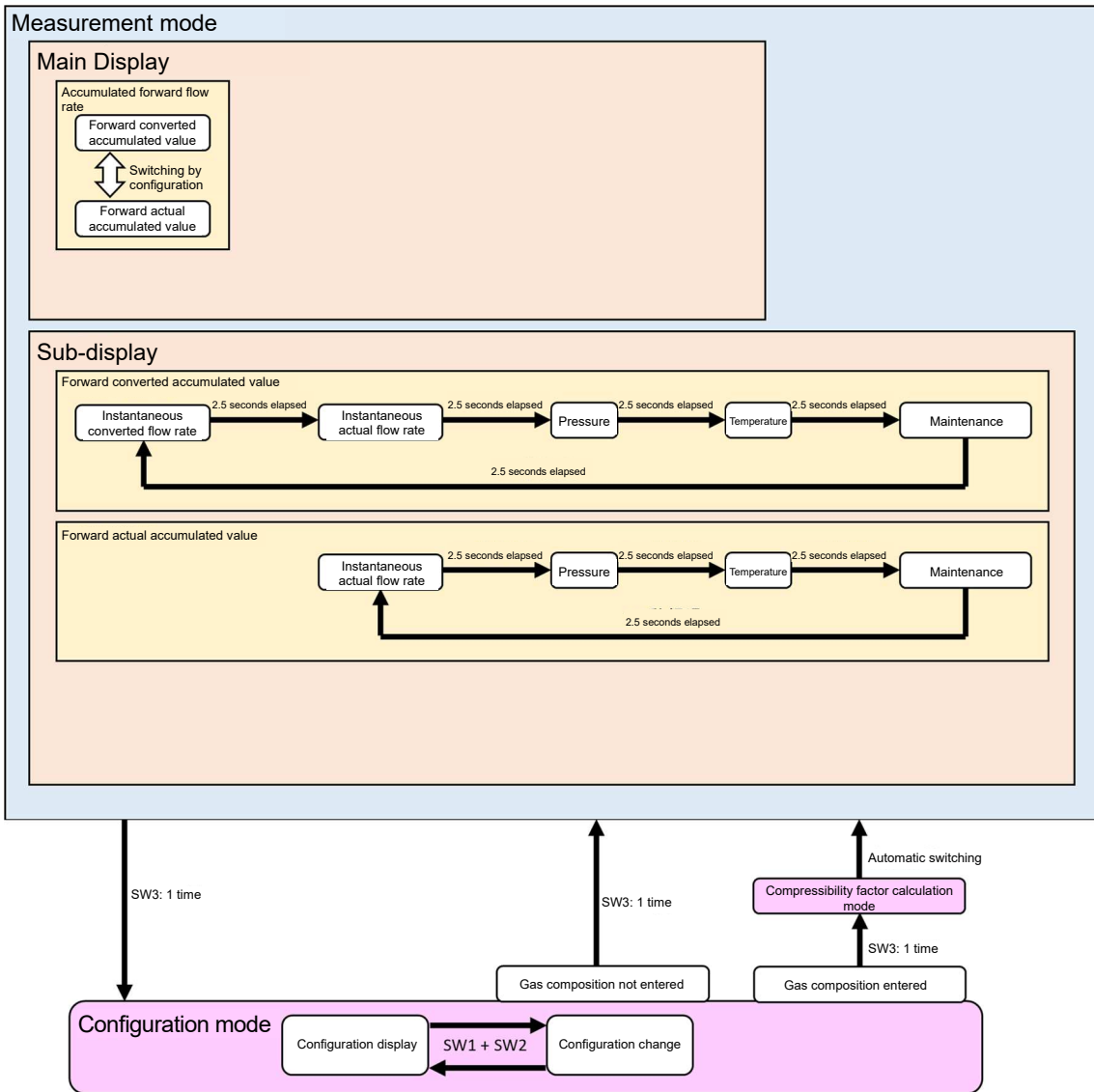
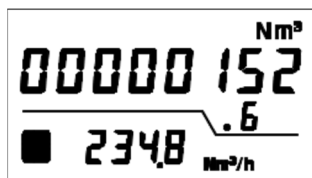

Fig. 7-1. Method of Switching Displays and Entering Various Modes in Measurement Mode

B. Functions in each mode

1) Measurement mode

- Main display section (upper part)



Forward converted accumulated value (Nm³)

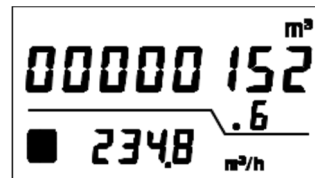

Forward actual accumulated value (m³)

- Sub-display section (lower part)

The following items are automatically switched every 2.5 seconds according to the flow conversion setting (converted flow rate or actual flow rate).

Converted flow rate display: instantaneous converted flow rate, instantaneous actual flow rate, pressure*¹, temperature, maintenance*²

Actual flow rate display: instantaneous actual flow rate, pressure*¹, temperature, maintenance*²

*1 The displayed pressure value will vary depending on whether the pressure sensor is installed or not.

Pressure sensor not installed: Displays the set absolute pressure.

Pressure sensor installed: Display the measured absolute pressure.

*2 Displays the success rate of ultrasonic measurement (the number of successful ultrasonic measurements in 10 measurements) in 4 levels.

(Number of Successes: Level 1: 0 to 2 times, Level 2: 3 to 5 times, Level 3: 6 to 8 times, Level 4: 9 to 10 times)

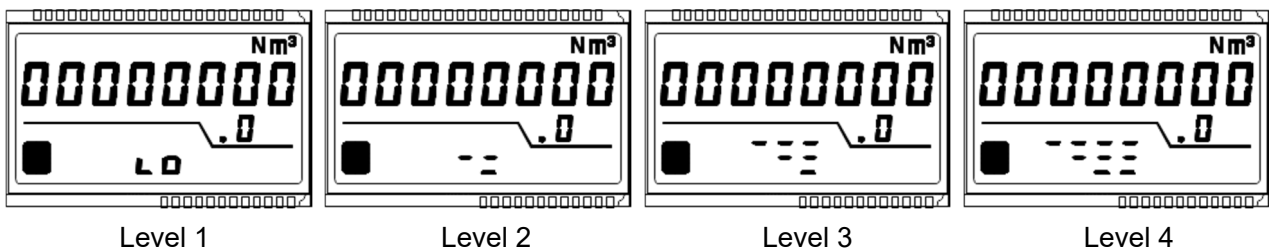

2) Configuration mode

(1) Press "SW3" once to shift from measurement mode to configuration mode. Press "SW3" again to shift from configuration mode to measurement mode. To press "SW3," use the supplied hexagonal wrench or similar tool.

⚠ Do not press "SW3" with a sharp object as it may cause damage.

(2) In the configuration mode, you can change the settings shown in "Table 3-1. Configuration Items and Standard Factory Settings."

(3) Refer to "Fig. 3-1. Display Switching Flow" for how to operate the buttons in the configuration mode.

8. Error Display and Output

1) Ultrasonic measurement error

[Status] Ultrasonic measurement has failed.

[Display] Instantaneous flow rate is displayed as "0.00" and "ALARM1" in the upper left corner of the LCD screen turns on.

The accumulated flow rate stops accumulating with the value displayed immediately before the error occurred.

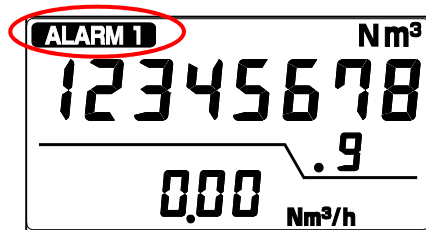

[Output] Flow rate pulse output: Stopped

[Cause] Foreign matter (fluid such as oil) that interferes with the propagation of ultrasonic waves may adhere or stay inside the measurement pipe. If the alarm display does not disappear after removing the foreign matter, please contact us.

2) Battery voltage drop error

[Status] The built-in battery is depleted.

[Display] "ALARM2" in the upper center of the LCD screen turns on.

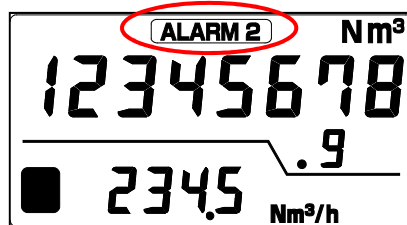

[Output] Flow rate pulse output: Normal operation

[Measures] After "ALARM2" turns on, you can measure (at room temperature) for about one (1) month, but please replace the unit as soon as possible.

3) Pressure value error

[Status] Pressure sensor failure, etc.

[Display] The instantaneous flow rate is "0.00" and the pressure indicates the detected error value and blinks. (Temperature display and maintenance display remain lit.)

The accumulated flow rate stops accumulation mode with the value displayed immediately before the error occurred.

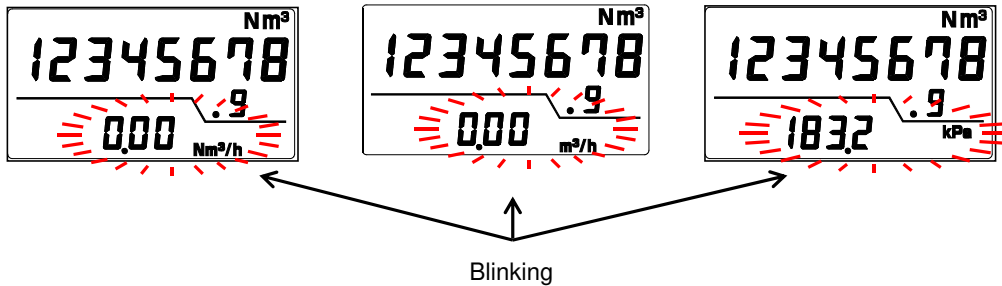

[Output] Flow rate pulse output: Stopped

[Measures] Please consult with us.

4) Temperature value error

[Status] Temperature sensor failure, etc.

[Display] The instantaneous flow rate is "0.00" and the temperature indicates the detected error value and blinks. (Pressure display and maintenance display remain lit.)

The accumulated flow rate stops accumulation mode with the value displayed immediately before the error occurred.

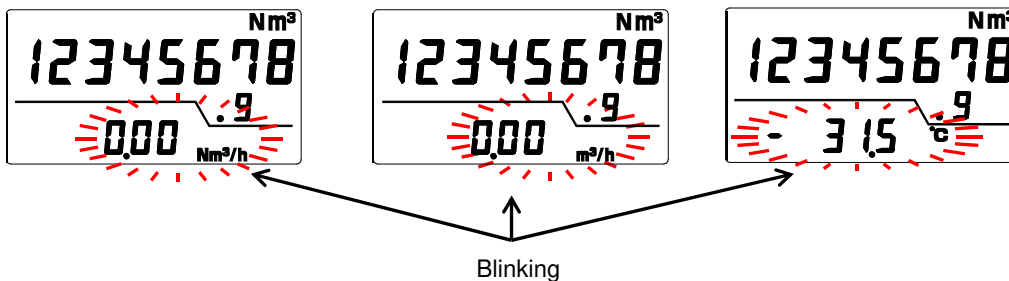

[Output] Flow rate pulse output: Stopped

[Measures] Please consult with us.

9. Specifications

Nominal Diameter		25A	32A	40A	50A	80A	100A	150A	200A
Power Supply		Built-in lithium thionyl chloride battery, battery life 11 years (Includes 1 year storage period) (At an ambient temperature of 20°C)							
Measurable fluids ^{*1)}	AS-W	Natural gas							
	AS-C	Air							
Pressure Sensor		A: Absolute Pressure Sensor							
Working Pressure (Absolute Pressure)	AS-W	0.07 to 0.5 MPa specification (AS-W-**-500BA) (AS-W-**-0BA) 0.07 to 0.2 MPa specification (AS-W-**-200BA)		0.07 to 1.0 MPa specification (AS-W-**-1000BA) (AS-W-**-0BA) 0.07 to 0.5 MPa specification (AS-W-**-500BA) 0.07 to 0.2 MPa specification (AS-W-**-200BA)				0.07 to 0.15 MPa specification (AS-W-**-200BA) (AS-W-**-0BA)	
	AS-C ^{*2)}	0.07 to 1.0 MPa specification (AS-C-**-1000BA)							
Flow Rate Range (Actual Flow Rate) ^{*3)} [m ³ /h]		±0.7 to 35	±1.3 to 65	±1.6 to 80	±3 to 150	±6 to 300	±10 to 500	±24 to 1200	±40 to 2000
Flow Rate Measurement Accuracy	±5%RD [m ³ /h] (or more to less than)	0.7 to 3.5	1.3 to 6.5	1.6 to 8	3 to 15	6 to 30	10 to 65	24 to 120	40 to 200
	±2%RD [m ³ /h] (or more to or less)	3.5 to 35	6.5 to 65	8 to 80	15 to 150	30 to 300	50 to 500	120 to 1200	200 to 2000
Flow Rate Conversion Error ^{*4)}		±1.8%							
Standard Low Flow Cut-off [m ³ /h or less]		±0.1	±0.2	±0.2	±0.4	±0.8	±1.5	±3.2	±5.7
Pressure Loss		Almost zero (equivalent to straight pipe)							
Fluid Temperature and Humidity		-20 to +40°C 90%RH or Less							
Display	Accumulated Flow Rate	00000000.0 Nm ³ 9 digits (AS-WE-40, 50, 80) 0000000000 Nm ³ 10 digits (AS-WE-100, 150, 200)							
	Instantaneous Flow Rate	(1) Maximum Display ±19999 Nm ³ /h (Converted Flow Rate) (2) Maximum Display ±19999 m ³ /h (Actual Flow Rate) (Less than 200 is displayed to 2 decimal places, 200 to less than 2000 is displayed to 1 decimal place, and 2000 or more is displayed to integer.)							
	Units	Display value × 1							Display value × 10
	Temperature	00.0°C 3 digits							
	Pressure	0000.0 kPa 5 digits							
	Maintenance	Success rate of ultrasonic measurement is displayed in 4 levels.							
	Alarm	ALARM1 (ON): Ultrasonic wave signal is low or cannot be received ALARM2 (ON): Battery voltage drops Sub-display section (Blinking): Temperature or pressure value is abnormal.							

Nominal Diameter		25A	32A	40A	50A	80A	100A	150A	200A
Output	Communication	RS485 MODBUS/RTU							
	External Power Supply	+9 to +26.4 VDC							
	Rated Voltage	-9 to +9 VDC							
	Contact Output	Nch open drain output Contact output 1: Unit pulse (forward flow), Pulse output unit: 100, 1000, 10000 L/P or NL/P Maximum rated voltage: 26.4 VDC Maximum rated current: 50 mA Saturation voltage at ON: 1.5 V or less Saturation current at OFF: 50 μ A or less							
History Storage Function ^{*5)}	Stored Items	Following 11 items: Instantaneous converted flow rate, instantaneous actual flow rate, pressure, temperature, forward converted accumulated value, forward actual accumulated value, reverse converted accumulated value, storage time, forward converted accumulated value (volume) used during storage period, forward actual accumulated value (volume) used during storage period, and error information							
	Number of Stored Data	6600 data (Eleven stored items are considered a single data item.)							
	Storage Interval	5 minutes to 24 hours (can be changed in increments of 5 minutes)							
Response		2 seconds				3 seconds			
Connection Method		ISO7005-1 (GB/T9119-2000 PN1.6 MPa flange)							
Mounting Orientation		Horizontal or Vertical (It is prohibited to install the display section downward.)							
Gas Contact Material		Aluminum alloy		Stainless alloy					
		PPS, fluorosilicone rubber, etc.							
Weight		3.5 kg	4.2 kg	8.4 kg	10.4 kg	14.1 kg	14.0 kg	21.2 kg	36.2 kg
Installation Location		Indoor or Outdoor (IP65 equivalent)							
Storage Temperature		-25 to +70°C, non condensing							

*1) See Table 9-1 for details.

*2) Negative pressure fluid cannot be measured.

*3) See Table 9-2 for the converted flow rate range.

*4) Conversion error when each pressure sensor is at F.S. (temperature range: -20 to 40°C).

*5) Refer to the communications specifications for details.

Table 9-1. Availability of Measurement for Methane Concentration

Nominal Diameter	Methane Concentration Range	Working Pressure (absolute)
200A	Over 99 to 100%	Not available
	97% or less	No restrictions
150A	Over 98 to 100%	100 kPa or more
	98% or less	No restrictions

*No restriction for the 100A or lower models.

Table 9-2. Converted Flow Rate Value [Conversion Example]

Conversion Temperature [°C]		0 (Nm ³ /h)				20 (S*m ³ /h)			
Conversion Pressure		1atm				1atm			
Working Pressure [MPa]		0.10133		0.15		0.10133		0.15	
Working Temperature [°C]		0	30	0	30	0	30	0	30
25A	0.7 [m ³ /h]	0.7	0.6	1.0	0.9	0.8	0.7	1.1	1.0
	35 [m ³ /h]	35.0	31.5	51.8	46.7	37.9	33.3	55.6	50.1
32A	1.3 [m ³ /h]	1.3	1.2	1.9	1.7	1.4	1.2	2.1	1.9
	65 [m ³ /h]	65.0	58.6	96.2	86.7	69.8	61.8	103.3	93.0
40A	1.6 [m ³ /h]	1.6	1.4	2.4	2.1	1.7	1.5	2.5	2.3
	80 [m ³ /h]	80.0	72.1	118.4	106.7	84.4	76.0	124.9	112.6
50A	3 [m ³ /h]	3.0	2.7	4.4	4.0	3.2	2.9	4.7	4.2
	150 [m ³ /h]	150.0	135.2	222.0	200.1	158.2	142.6	234.2	211.1
80A	6 [m ³ /h]	6.0	5.4	8.9	8.0	6.3	5.7	9.4	8.4
	300 [m ³ /h]	300.0	270.3	444.1	400.1	316.5	285.2	468.5	422.1
100A	10 [m ³ /h]	10.0	9.0	14.8	13.3	10.5	9.5	15.6	14.1
	500 [m ³ /h]	500.0	450.5	740.2	666.9	527.5	475.3	780.8	703.5
150A	24 [m ³ /h]	24.0	21.6	35.5	32.0	25.3	22.8	37.5	33.8
	1200 [m ³ /h]	1200.0	1081.2	1776.4	1600.6	1265.9	1140.6	1873.9	1688.5
200A	40 [m ³ /h]	40.0	36.0	59.2	53.4	42.2	38.0	62.5	56.3
	2000 [m ³ /h]	2000.0	1802.1	2960.6	2667.6	2109.8	1901.0	3123.2	2814.1

*Even in the standard conversion mode, the LCD screen displays values in Nm³/h.

10. External View

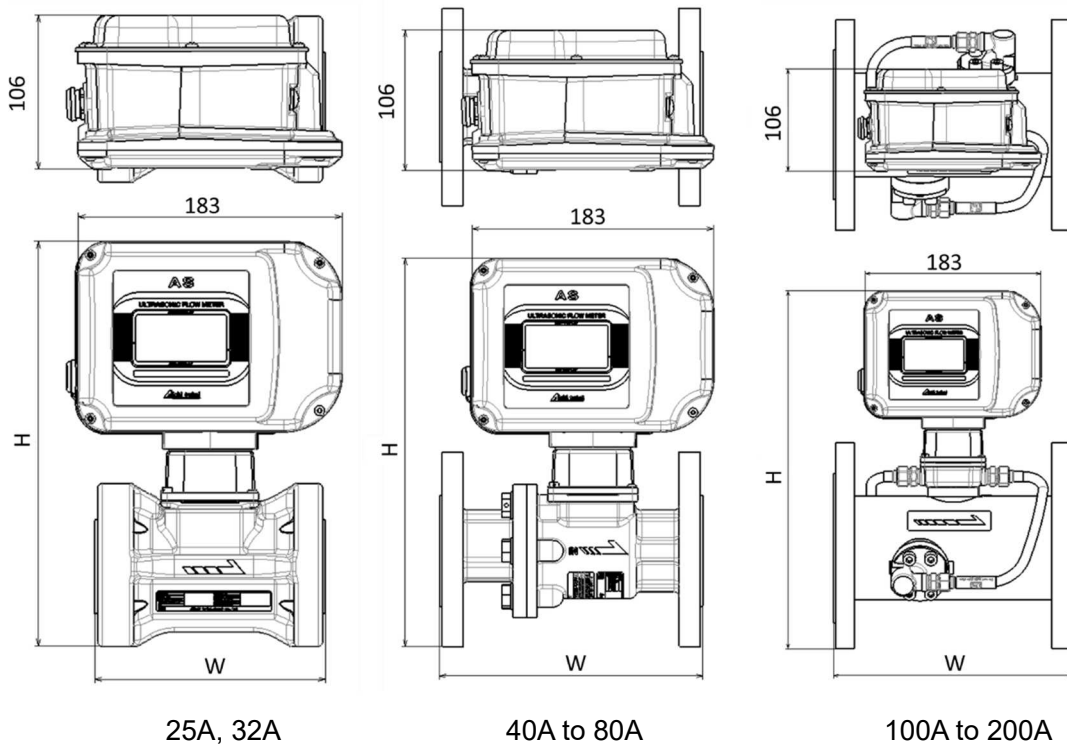

Fig. 10-1. External View

Model	W [mm]	H [mm]
AS - [Specification] - 25 - [Pressure Sensor Specification] BA/5	160	272
AS - [Specification] - 32 - [Pressure Sensor Specification] BA/5	160	272
AS - [Specification] - 40 - [Pressure Sensor Specification] BA/5	200	297
AS - [Specification] - 50 - [Pressure Sensor Specification] BA/5	220	311
AS - [Specification] - 80 - [Pressure Sensor Specification] BA/5	250	343
AS - [Specification] - 100 - [Pressure Sensor Specification] BA/5	250	377
AS - [Specification] - 150 - [Pressure Sensor Specification] BA/5	300	434
AS - [Specification] - 200 - [Pressure Sensor Specification] BA/5	350	492

11. Battery Life

The built-in battery life is 11 years. (Includes 1 year storage period. This is guaranteed at an ambient temperature of 20°C.)

If the battery runs out, please contact us.

12. Troubleshooting

Timing	Phenomenon	Possible Cause	Coping Methods
Immediately after installation	ALARM1 turns on.	A fluid other than that specified is flowing.	Check and follow the precautions in "For Safe and Proper Use" [pages 3 to 5] and "Specifications" [pages 29 and 30].
		Flow meter is used outside the specification range (installation conditions, pressure, temperature, etc.).	
		Foreign matter is adhered to the inside of the measurement part or to the ultrasonic sensor.	Check for and remove any foreign matter.
		There is a large electrical noise source near the flow meter.	Eliminate the noise source or shield the flow meter. Ground the braided shield when using the external connection cable. [See page 23.]
	Accumulation does not start immediately after installation.	Adjustment operation for pressure fluctuation is in progress.	Check that the divider line between the main display and the sub-display is blinking. Blinking stops after about a minute and accumulation operation starts.
	Displayed instantaneous flow rate is negative.	The direction of fluid flow and the arrow flow direction of the flow meter are opposite.	Check that the arrow direction on the outside surface of the flow meter is aligned with the direction of fluid flow.
After Operation	ALARM2 turns on.	Battery voltage is low.	The built-in battery is running out of power. Please contact us.
	Sub-display blinks. (Instantaneous standard flow rate, instantaneous actual flow rate, and pressure are blinking.)	Pressure sensor is faulty.	Please contact us.
	Sub-display blinks. (Instantaneous standard flow rate, instantaneous actual flow rate, and temperature are blinking.)	Temperature sensor is faulty.	Please contact us.
	Instantaneous flow rate fluctuates greatly.	Pressure frequently fluctuates.	Flow meter is operating normally. To reduce instantaneous flow fluctuations, it is recommended that the flow meter be installed in a location where pressure fluctuations are small.
		There is a pulsation.	Measurement cannot be performed correctly in a pulsating environment. Install the flow meter in a place where there is no pulsation.
		There is a pressure reducing valve near the flow meter.	Flow meter is operating normally. To reduce instantaneous flow fluctuations, it is recommended to install the flow meter away from the pressure reducing valve. (See Fig. 4-2 [page 20].)
	Displayed instantaneous flow rate does not become zero even though there is no flow.	Gas is circulating through the piping.	Flow meter is operating normally.
	The instantaneous flow rate is too high.	The length of the straight pipe is insufficient.	Depending on the piping conditions, install a straight pipe of the recommended length in the upstream and downstream of the flow meter. (See Fig. 4-1 [page 19].)
	The instantaneous flow rate is too low.		
	The instantaneous flow rate does not appear to change.	Excessive flow exceeding the specification range is flowing.	Use within the specification range. (See [page 29 and 30].)
	The divider line between the main display and the sub-display is blinking.	Adjustment operation for pressure fluctuation is in progress.	Blinking stops after about a minute and accumulation operation starts.
	ALARM1 turns on.	Foreign matter is adhered to the inside of the measurement part or to the ultrasonic sensor.	Clean the inside of the measurement pipe according to the following method. Repeat the cleaning procedure until the ALARM1 turns off. *1 Do not hold the display section while cleaning. *2 Do not touch the ultrasonic sensors. <In case of dirt adhesion due to oil> (1) Seal one side of the measurement part (pipe). (2) Pour spindle oil into the measurement part and leave it in place for 1 to 2 hours. (3) Spend over an hour to drain the spindle oil. <In case of dirt adhesion due to something other than oil> (1) Seal one side of the measurement part (pipe). (2) Pour water into the measurement part and gently shake it up and down 4 to 5 times. If the dirt is not removed, repeat the procedure. (3) Drain the water from the measurement part and allow to dry naturally.
			The operating conditions have changed and the flow meter is used outside the specification range (installation conditions, pressure, temperature, etc.).

If the troubleshooting procedures do not resolve the problem, please contact us

Memo

- Warranty and After-Sales Service

1) Warranty Period

For a period of one (1) year from the date of purchase, we will deliver a replacement product free of charge if the failure is clearly attributable to a fault in our manufacturing process.

2) Scope of Warranty

The warranty does not cover the following cases:

- Failure caused by force majeure such as natural disasters, conflicts, and disasters.
- Failure caused by disassembly or modification.
- Failure caused by improper handling.
- Failure caused by use outside the scope of the specifications (e.g., environment).
- Other cases that are deemed outside the scope of our responsibility.

The warranty described here refers to the warranty for our products alone, and does not cover any damage to the customer caused by the failure of our products (damage or injury to other than our products, lost profits, opportunity losses, transportation costs, construction costs, etc.).

3) Requesting for Service

Regardless of whether you are under warranty, please provide us with the product name, model (AS-W or AS-C), construction number, serial number and option availability, and as much detail as possible regarding the failure.