

Small-Size Electromagnetic Sensor VN Handling Manual



	This indicates that if you ignore this instruction, danger which may result in death or serious injury can occur.
	This indicates that if you ignore this instruction, danger which may result in injury can occur.
	This indicates that if you ignore this instruction, a physical damage (e.g., defect of the product) can occur.

Notes on use

	<ol style="list-style-type: none"> Do not use this product for a purpose which requires safety, such as atomic power generation, railways, aviation, vehicle, or playground equipment. Do not alter the product. Do not use this product for food, beverage, and/or medical fluid because it does not conform to the sanitary specifications. Do not use in an explosive atmosphere such as a combustible gas because it is not explosion-protected. Do not expose the product to a corrosive fluid.
--	---

Use environment and target fluid

	<ol style="list-style-type: none"> The target fluid is even water with conductivity of 50 μS/cm or higher. Make sure to observe the applicable range of conductivity. In particular, this product cannot used with fluid which conductivity is extremely low, such as pure water or oil. Never install the sensor unit where the fluid can freeze or its temperature can exceed 60°C. The product may malfunction if it is used within fluid where a stray current is flowing. Observe the permissible pressure range (1 MPa or less). Since the product is not water-proof (IP64 equivalent), do not install it where it can be submerged. Do not get a strong magnet or magnetic field close to the flowsensor.
--	---

Notes on operation

	<ol style="list-style-type: none"> This product cannot be used for billing application. Do not use any display or output during 20 seconds after power on until operation becomes stable.
--	---

Piping

	<ol style="list-style-type: none"> Do not use the product where air can ingress. Also, do not install it where a air pocket can easily occur (e.g., the upstream side of a falling pipe). Before starting to use the product after installation, drain air sufficiently. It is recommended to install the sensor as the LED seal surface becomes parallel to the ground or fluid flows from the bottom to the top in order to avoid influence by bubble, dust and/or dirt, etc. Install something that disturbs the flow such as flow adjustment valve at the downstream of the product. Do not install the product on a piping system where an impact pressure such as a water hammer can occur. Wash a new pipe thoroughly before installing it and using the product with it. Do not install the product where a strong compression tension force or a strong load is applied to it. Put and install the sensor in accordance with the flow direction indicated on the product. Make sure that the sealing tape used for installation of the sensor unit does not get into the inside of the pipe. Make sure that no burr exists with the end of the pipes connected to the product. Do not drop, hit, or apply an excessive impact to the product. Hold the body when you handle the product (never hold the cable).
	<ol style="list-style-type: none"> Observe the specified tightening torque shown below. Do not apply an excessive torque. An excessive torque may break the sensor sleeve screw section and cause leakage. VN05R: 3.0\pm0.5 Nm VN10R: 5.0\pm0.5 Nm VN20R: 1 2 \pm 1 Nm If the fluid still leaks after tightening the screws with the above torque, do not tighten them with a higher torque but check the screws and sealing tape for defects. Do not install in locations used as footholds .

Cabling

	<ol style="list-style-type: none"> This products operates with 12 to 24VDC. Connecting it to a AC power supply may cause a fire. Observe the instructions given in this manual for cabling. Observe the rated range. Do not use a load exceeding the permissible value.
	<ol style="list-style-type: none"> Keep the cables away from the power and motor cables. Keep the product away from noise sources as far as possible. It is recommended to electrically isolate power supply and receiving instruments from other equipment. Do not apply an excessive tension to the cables. Be careful so that the cable tip is not soaked in water during the cabling work.

Checking specifications

- Confirm that the specifications indicated on the seals attached to the top of the package as well as to the back of the sensor are identical to those ordered.
- Be sure to confirm the specifications for both of the two output channels (channels 1 and 2).

Wiring

- Refer to the figure below for electrical connection.

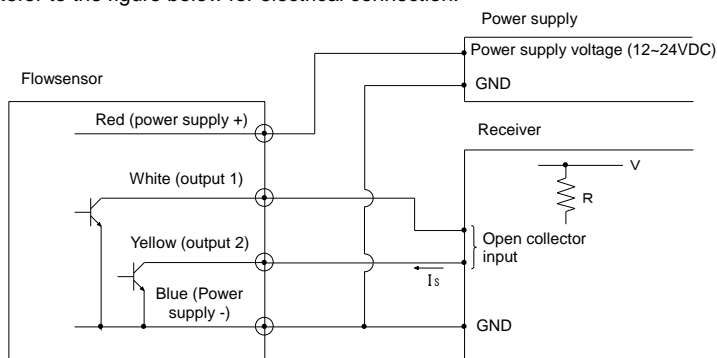

$$I_s \text{ (Output sink current)} = \frac{V \text{ (Pull-up voltage)}}{R \text{ (Pull-up resistance)}} \leq 20\text{mA}$$

Keep the pull-up voltage at 30V or less and output sink current for each channel at 20 mA or less.

LED indication

- A bicolor (green/red) LED indicates the flow rate or alert. An alert caused by detection of abnormality is prioritized, and only an alert with the highest priority is indicated.

Green: Indicates the flow rate with four blinking and lighting patterns in three levels.

Red: Indicates an alert (fault detection) with six blinking and lighting on/off patterns in four levels.

1. Flow rate (green)

- Flow rate range and display pattern

Flow rate range	Display pattern
Less than low-flow-cut flow rate	Turns on continuously.
low-flow-cut flow rate to 1/3 of the upper limit of the accuracy-guaranteed flow rate	Blinks at 2-second interval by turning on and off for 1 second respectively.
1/3 to 2/3 of the upper limit of the accuracy-guaranteed flow rate	Blinks at 1-second interval by turning on and off for 0.5 seconds respectively.
Higher than 2/3 of the upper limit of the accuracy-guaranteed flow rate	Blinks at 0.4-second interval by turning on and off for 0.2 seconds respectively.

(Low-flow-cut flow rate to 1/3 of the upper limit of the accuracy-guaranteed flow rate)

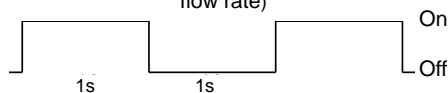

(1/3 to 2/3 of the upper limit of the accuracy-guaranteed flow rate)

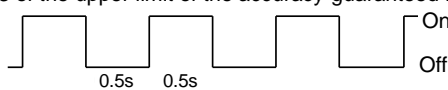

(Higher than 2/3 of the upper limit of the accuracy-guaranteed flow rate)



2. Alert (red)

- Alert items

Excitation failure	Current does not flow through the excitation coil correctly.
Memory error	Error has been detected with memory data.
Voltage drop	Power supply voltage has dropped.
Dry sensor	Target fluid has gone out of the flowsensor and the sensor is not filled with it.
Excessive fluid noise	Normal measurement is not possible since an abnormal current is flowing through the target fluid or air is mixed in it.
Reverse flow	Target fluid is flowing in the reverse direction.
Excessive flow	125% or more of the maximum flow rate for the model has been detected.

- Alert items and display pattern

Alert item	Priority	Display pattern
Voltage drop	1	Turns on continuously for both red and green.
Excitation failure or memory error	2	Turns on continuously.
Dry sensor	3	Turns on and off for 0.3 seconds respectively for one cycle, and then turns off for 1.7 seconds.
Excessive fluid noise	4	Turns on and off for 0.3 seconds respectively for two cycles, and then turns off for 1.7 seconds.
Reverse flow	5	Turns on and off for 0.3 seconds respectively for three cycles, and then turns off for 1.7 seconds.
Excessive flow	6	Turns on and off for 0.3 seconds respectively for four cycles, and then turns off for 1.7 seconds.

Dry sensor



Excessive fluid noise

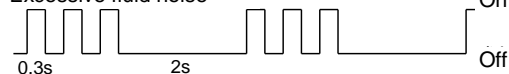

Reverse flow



Excessive flow



Warranty

•Warranty period

One year after the dispatch date from Aichi tokei denki facility.

•Warranty scope

We are making every effort to produce our products with high quality, however if a defect which is subject to our liability should occur during the warranty period under normal use, we shall repair the product or replace it with a normal product for free.

Please understand that we shall determine whether the free remedy shall apply to your situation after our investigation of the product. Also please understand that the free remedy shall not be applied to a defect:

- 1) Caused by use which does not follow the instructions given in our catalog, product specifications, and/or handling manual,
- 2) Caused by disaster such as a fire, earthquake, storm, flood, or lightning, or a destructive act such as a crime,
- 3) Caused by corrosion due to use in a corrosive environment,
- 4) Caused by acts of animals such as a dog, cat, rat, or insect,
- 5) Caused by a factor other than our product,
- 6) Which could not be foreseen with the science and technology levels at the time of shipment,
- 7) Caused by a repair or alteration other than done by or specified by us, and/or
- 8) Caused by an inappropriate inspection and/or maintenance or replacement of a consumable.

Please note that "warranty" in this context means warranty for our product alone and we shall not be reliable for any damage resulting from a defect of our product, including but not limited to a damage to equipment other than our product, loss of profit, loss of opportunity, transportation fee, and construction fee.



1-2-70 Chitose, Atsuta-ku, Nagoya, Aichi Prefecture 456-8691 JAPAN

Contact us : Overseas Business Division

TEL. +81-(0)52-661-5150

FAX. +81-(0)52-661-6418

Aichi Tokei Denki homepage: <https://www.aichitokei.co.jp/>

Ver. 0
202211

The product specification might be changed without prior notice.